

© International Baccalaureate Organization 2024

All rights reserved. No part of this product may be reproduced in any form or by any electronic or mechanical means, including information storage and retrieval systems, without the prior written permission from the IB. Additionally, the license tied with this product prohibits use of any selected files or extracts from this product. Use by third parties, including but not limited to publishers, private teachers, tutoring or study services, preparatory schools, vendors operating curriculum mapping services or teacher resource digital platforms and app developers, whether fee-covered or not, is prohibited and is a criminal offense.

More information on how to request written permission in the form of a license can be obtained from <https://ibo.org/become-an-ib-school/ib-publishing/licensing/applying-for-a-license/>.

© Organisation du Baccalauréat International 2024

Tous droits réservés. Aucune partie de ce produit ne peut être reproduite sous quelque forme ni par quelque moyen que ce soit, électronique ou mécanique, y compris des systèmes de stockage et de récupération d'informations, sans l'autorisation écrite préalable de l'IB. De plus, la licence associée à ce produit interdit toute utilisation de tout fichier ou extrait sélectionné dans ce produit. L'utilisation par des tiers, y compris, sans toutefois s'y limiter, des éditeurs, des professeurs particuliers, des services de tutorat ou d'aide aux études, des établissements de préparation à l'enseignement supérieur, des fournisseurs de services de planification des programmes d'études, des gestionnaires de plateformes pédagogiques en ligne, et des développeurs d'applications, moyennant paiement ou non, est interdite et constitue une infraction pénale.

Pour plus d'informations sur la procédure à suivre pour obtenir une autorisation écrite sous la forme d'une licence, rendez-vous à l'adresse <https://ibo.org/become-an-ib-school/ib-publishing/licensing/applying-for-a-license/>.

© Organización del Bachillerato Internacional, 2024

Todos los derechos reservados. No se podrá reproducir ninguna parte de este producto de ninguna forma ni por ningún medio electrónico o mecánico, incluidos los sistemas de almacenamiento y recuperación de información, sin la previa autorización por escrito del IB. Además, la licencia vinculada a este producto prohíbe el uso de todo archivo o fragmento seleccionado de este producto. El uso por parte de terceros —lo que incluye, a título enunciativo, editoriales, profesores particulares, servicios de apoyo académico o ayuda para el estudio, colegios preparatorios, desarrolladores de aplicaciones y entidades que presten servicios de planificación curricular u ofrezcan recursos para docentes mediante plataformas digitales—, ya sea incluido en tasas o no, está prohibido y constituye un delito.

En este enlace encontrará más información sobre cómo solicitar una autorización por escrito en forma de licencia: <https://ibo.org/become-an-ib-school/ib-publishing/licensing/applying-for-a-license/>.

Biology
Standard level
Paper 1

13 May 2024

Zone A afternoon | **Zone B** afternoon | **Zone C** afternoon

45 minutes

Instructions to candidates

- Do not open this examination paper until instructed to do so.
- Answer all the questions.
- For each question, choose the answer you consider to be the best and indicate your choice on the answer sheet provided.
- The maximum mark for this examination paper is **[30 marks]**.

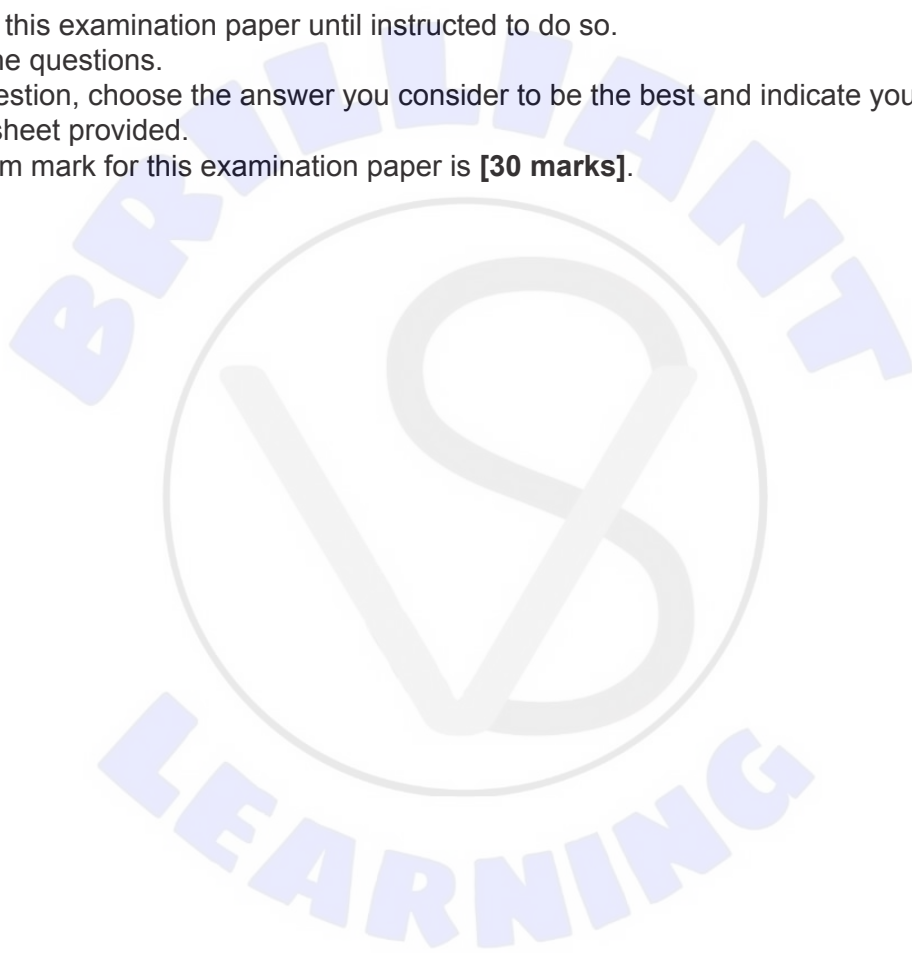

1. The image shows the nucleus of a cell from the pancreas that is surrounded by endoplasmic reticulum.

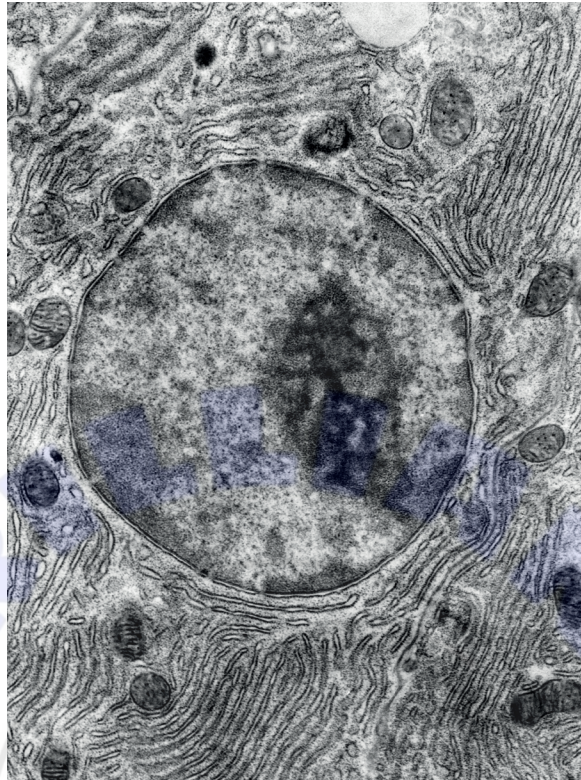

What describes this nucleus?

- A. It is composed of highly folded internal membranes and a liquid matrix.
- B. It contains ribosomes and is the main site of protein synthesis in a cell.
- C. It contains membrane-bound organelles.
- D. It contains chromatin and is surrounded by a double membrane.

2. The image shows a single *Paramecium* with food vacuoles that contain ingested cells of the unicellular green alga *Chlorella*.



What can be deduced about *Paramecium*?

- A. It is an autotroph.
- B. It cannot perform all of the functions of life.
- C. It carries out heterotrophic nutrition.
- D. It is a prokaryote.

Turn over

3. This micrograph is from a dividing cell.

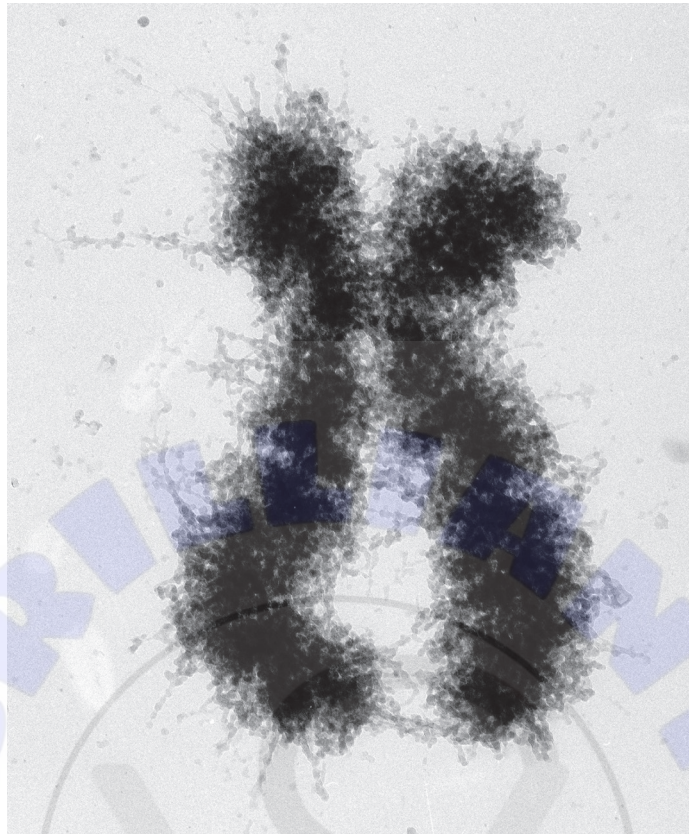

What is shown in this image?

- A. Two condensed chromosomes consisting of four chromatids
- B. A chromosome from a cell in telophase of mitosis
- C. A chromosome from a cell in G1 of interphase
- D. A chromosome from a cell in metaphase

4. The diagram shows the Davson–Danielli model of the cell membrane.

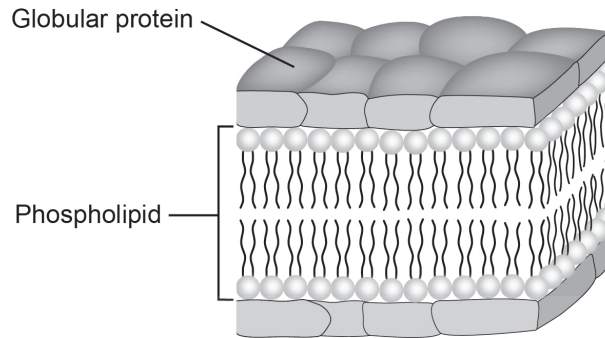

How does this model relate to the fluid mosaic model?

- A. Both models include a phospholipid bilayer sandwiched between two layers of protein.
 - B. The Davson–Danielli model does not include integral proteins, whereas the fluid mosaic model does.
 - C. The fluid mosaic model shows proteins sandwiched between two layers of phospholipid.
 - D. The Davson–Danielli model includes a phospholipid bilayer, whereas the fluid mosaic model does not.
5. How is a prokaryotic cell different from a eukaryotic cell?
- A. Eukaryotic cells are compartmentalized, whereas prokaryotic cells are not.
 - B. Prokaryotic cells do not contain ribosomes, whereas eukaryotic cells do.
 - C. Eukaryotic cells contain DNA, whereas prokaryotic cells do not.
 - D. Prokaryotic cells have a cell wall, whereas eukaryotic cells do not.

Turn over

6. The diagram shows two molecules which can be linked by a condensation reaction.

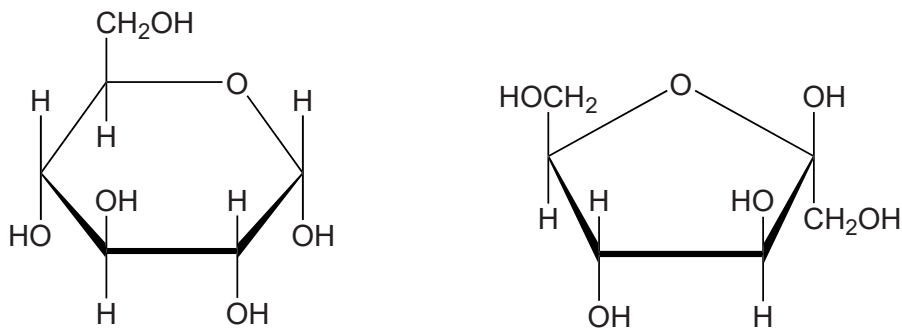

What would be the product(s) of this reaction?

- A. Water and sucrose
 - B. Water and maltose
 - C. A dipeptide
 - D. Lactose
7. The graph shows the effect of limiting factors on the rate of photosynthesis.

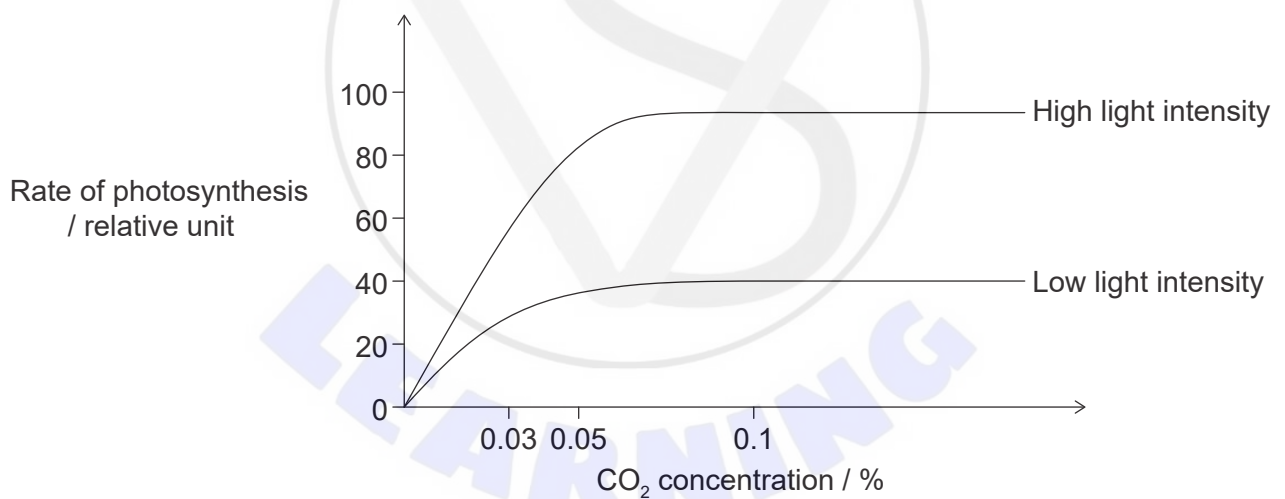

What can be concluded from this graph?

- A. At a CO₂ concentration of 0.1% and a low light intensity, temperature is the only limiting factor.
- B. At a CO₂ concentration of 0.1% and a low light intensity, light intensity is the only limiting factor.
- C. At a CO₂ concentration of 0.03% and a low light intensity, both CO₂ concentration and temperature are limiting factors.
- D. At a CO₂ concentration above 0.1%, there are no limiting factors.

8. How do human muscle cells respond to intense exercise?
- A. They stop using oxygen and replace glycolysis with lactic fermentation.
 - B. They produce smaller amounts of ATP in order to reduce the need for oxygen.
 - C. They produce lactate in order to quickly supply the energy for muscle contraction.
 - D. They produce ethanol and carbon dioxide as waste products.
9. Watson and Crick worked out the three-dimensional structure of DNA. What did the model they built show for the first time?
- A. DNA is a polynucleotide.
 - B. DNA contains equal quantities of adenine and thymine.
 - C. DNA molecules have a helical shape.
 - D. DNA is a double helix with antiparallel sugar-phosphate backbones.
10. What describes the structure of proteins?
- I. Proteins are made from amino acids linked together by peptide bonds.
 - II. The sequence of amino acids in all proteins is the same.
 - III. A protein may consist of more than one polypeptide.
- A. I and II only
 - B. I and III only
 - C. II and III only
 - D. I, II and III
11. What are components of DNA and RNA?

	DNA	RNA	Both DNA and RNA
A.	ribose	deoxyribose	uracil
B.	ribose	deoxyribose	adenine
C.	deoxyribose	ribose	uracil
D.	deoxyribose	ribose	adenine

Turn over

12. What is the role of DNA polymerase during DNA replication?

- A. It adds nucleotides to the growing strand.
- B. It adds nucleotides to the template strand.
- C. It builds messenger RNA.
- D. It carries out translation.

13. Huntington's disease is a neurodegenerative genetic disorder caused by a dominant allele. The pedigree chart for a family shows the inheritance of Huntington's disease.

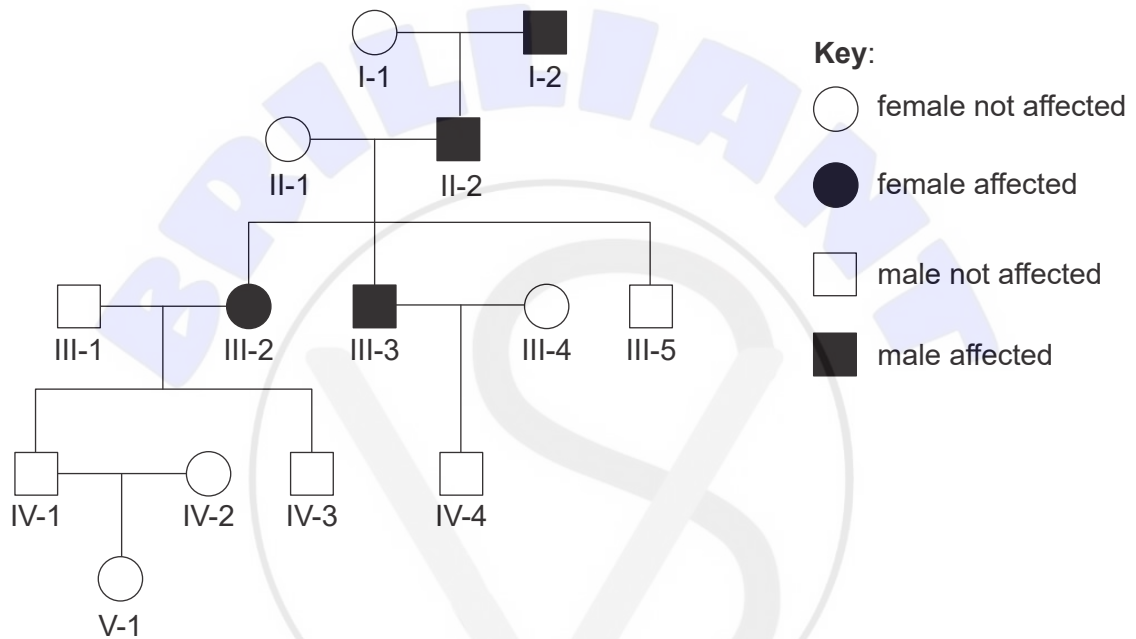

What can be concluded from this pedigree chart?

- A. Huntington's disease is sex-linked, since most affected individuals are male.
- B. Huntington's disease is not sex-linked, since individuals IV-1 and IV-3 are not affected.
- C. Huntington's disease is not sex-linked, since individual III-3 is affected.
- D. Individual IV-1 is a carrier, since individual III-2 is affected.

14. Which stage of DNA profiling involves the polymerase chain reaction (PCR)?
- A. During extraction of the DNA sample
 - B. During replication of the DNA that has been cut with restriction enzymes
 - C. During electrophoresis to separate the DNA fragments on a gel
 - D. During incubation with labelled probes
15. Which gas is the main contributor to the greenhouse effect?
- A. Ozone
 - B. Methane
 - C. Nitrogen oxide
 - D. Water vapour
16. In a stable natural ecosystem, how is the supply of nutrients and energy maintained?
- A. Nutrients and energy are efficiently cycled within the ecosystem.
 - B. Energy from the Sun is cycled through the food chains, while nutrients are constantly lost.
 - C. Nutrients are efficiently cycled within the ecosystem, while there is a constant flow of energy.
 - D. Energy is cycled through photosynthesis and respiration, while food chains ensure that nutrients flow through the ecosystem.
17. How are the individuals in an ecological community related to each other?
- A. They all belong to the same species.
 - B. They all belong to the same trophic level.
 - C. They belong to different populations.
 - D. They belong to populations composed of many species.

- 18.** How do autotrophs living in an aquatic ecosystem obtain carbon?
- A. By diffusion of dissolved carbon dioxide and hydrogen carbonate ions
 - B. By feeding on heterotrophs and obtaining carbon from carbohydrates
 - C. By active transport of carbon dioxide directly from the atmosphere
 - D. By ingesting organisms with carbonate shells
- 19.** In a natural classification, what do all members of a genus have in common?
- A. They all have the same binomial name.
 - B. They all belong to the same species.
 - C. They can freely interbreed to produce fertile offspring.
 - D. They have all evolved from the same common ancestor.

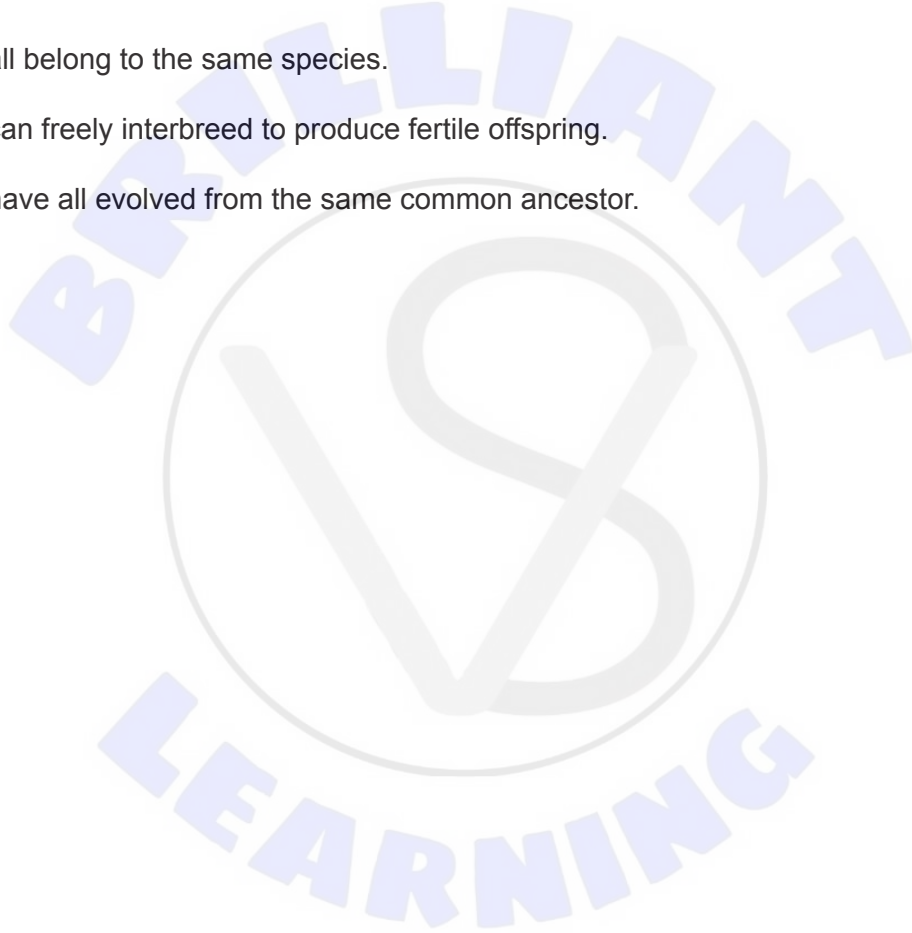

20. The cladogram shows the evolutionary relationships between a number of animal groups.

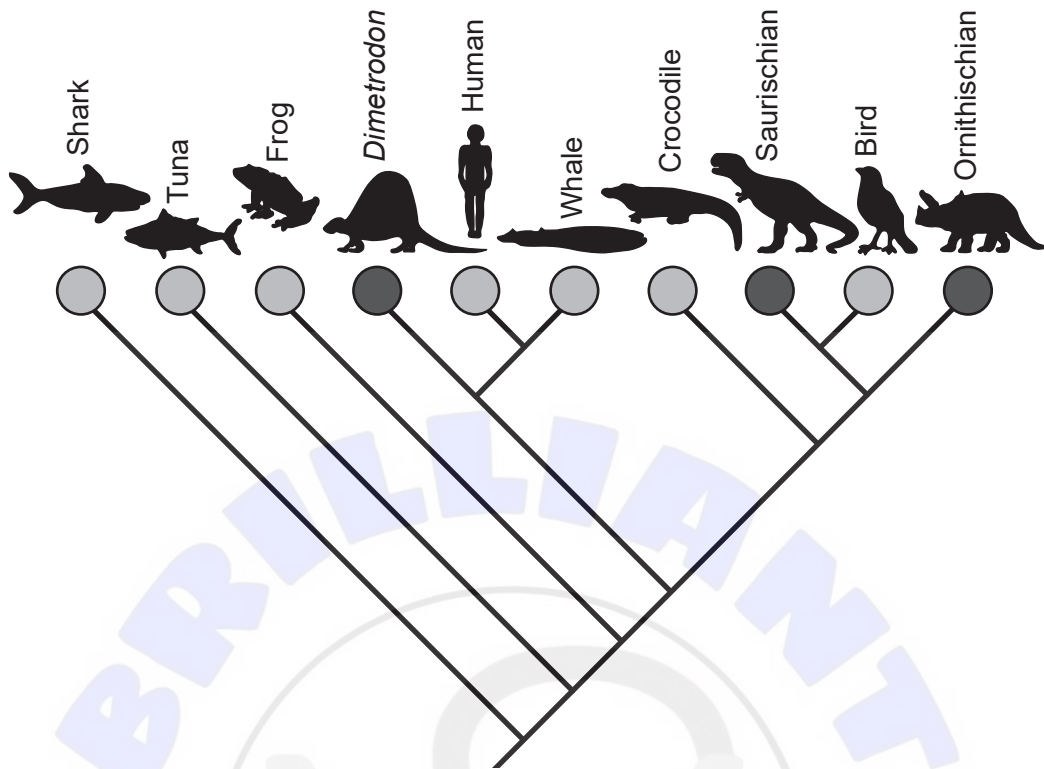

What can be concluded from this cladogram?

- A. Tuna evolved from sharks.
- B. Crocodiles are more closely related to birds than to whales.
- C. Frogs, humans and whales do not share a common ancestor.
- D. Shark and tuna evolved later than humans.

Turn over

21. A central idea in the theory of evolution is that species may evolve gradually over time from a common ancestor.

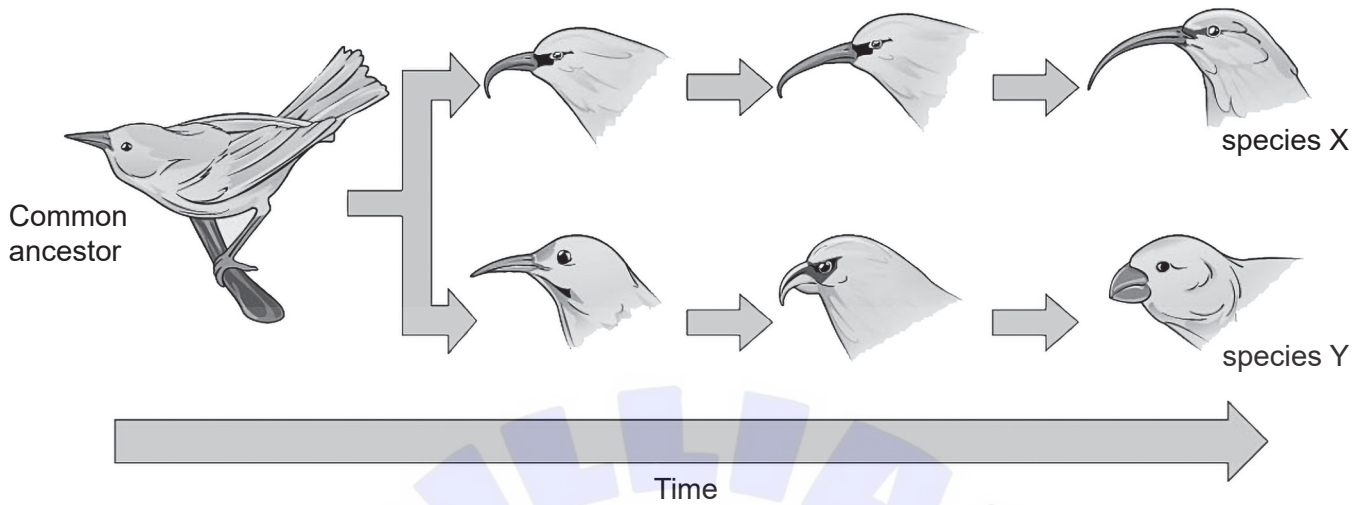

Which statement(s) explain(s) the pattern of evolution seen in the diagram?

- I. Beak shape shows genetic variability in the common ancestor.
 - II. Changes in beak shape that occur during the lifetime of an individual bird are passed on to the next generation.
 - III. Changes in beak shape are heritable and make each species better adapted to its environment.
- A. II only
 - B. I and II only
 - C. I and III only
 - D. I, II and III

22. The dichotomous key shown here can be used to distinguish six major animal phyla:

Porifera



Cnidaria

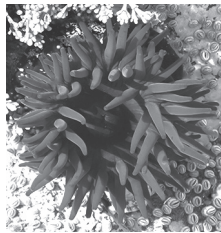

Platyhelmintha



Annelida



Mollusca

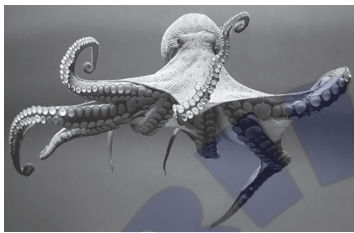

Arthropoda

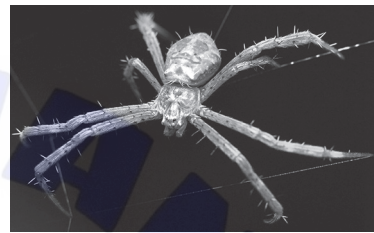

Based on this dichotomous key, which letter represents an organism in the phylum Mollusca?

- 1. Animal is symmetrical yes Go to 2.
 no *Porifera*
- 2. Animal has radial symmetry yes *Cnidaria*
 no Go to 3.
- 3. Animal has an anus yes Go to 4.
 no A.
- 4. Animal has a visibly segmented body yes Go to 5.
 no B.
- 5. Animal has an exoskeleton. yes C.
 no D.

Turn over

23. The diagram shows how heart sounds are aligned with the changes in blood pressure in the cardiac cycle.

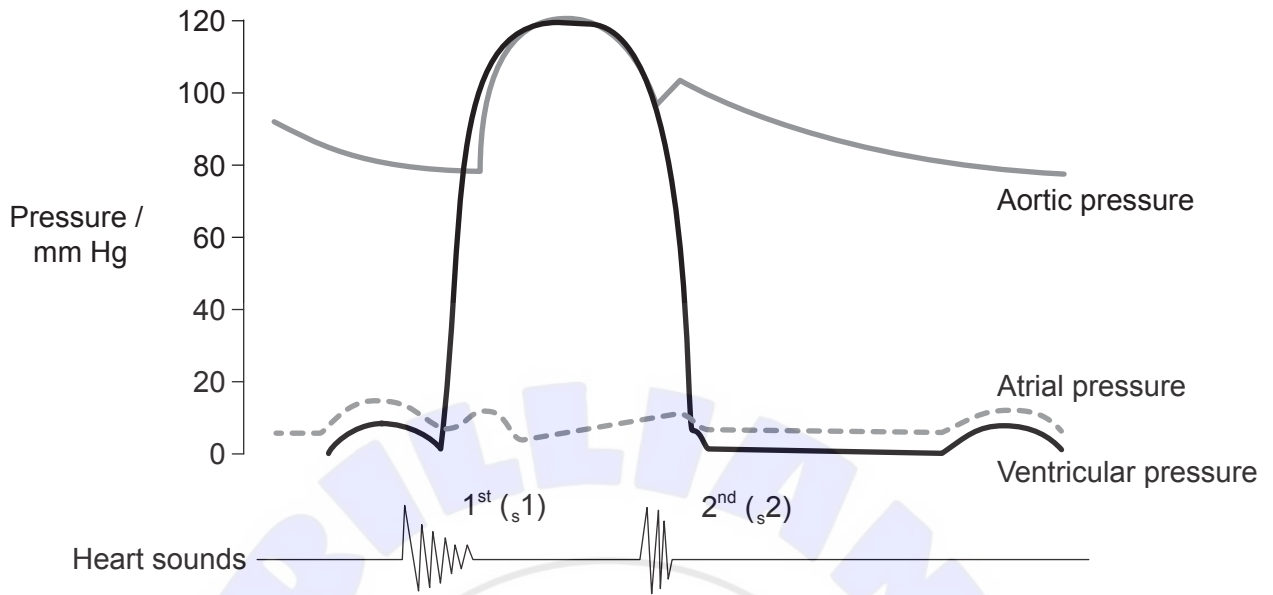

What can be deduced about the cause of the heart sounds?

- A. The 1st heart sound is caused by the closing of the atrio-ventricular valves
 - B. The 2nd heart sound is caused by the opening of the atrio-ventricular valves
 - C. The 1st heart sound is caused by the closing of the semi-lunar valves
 - D. The 2nd heart sound is caused by the closing of the atrio-ventricular valves.
24. What property of antibiotics makes them effective in the treatment of infectious diseases?
- A. They stimulate the production of antibodies.
 - B. They block metabolic pathways in prokaryotes.
 - C. They block the metabolic processes in viruses.
 - D. They inhibit mitosis in eukaryotes.

25. The diagram shows an alveolus from a healthy human lung with type I and II pneumocytes and phagocytes.

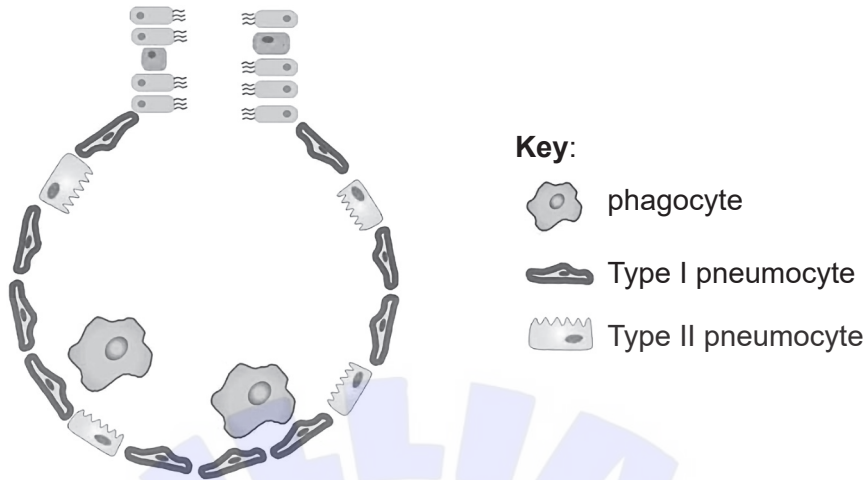

What are the main functions of these cells?

	Type I pneumocyte	Type II pneumocyte	Phagocyte
A.	Production of surfactant	Gas exchange	Production of antibodies
B.	Gas exchange	Production of surfactant	Production of antibodies
C.	Production of surfactant	Gas exchange	Ingestion of pathogens
D.	Gas exchange	Production of surfactant	Ingestion of pathogens

26. What distinguishes capillaries from other blood vessels?
- A. They have valves which allow blood flow in one direction only.
 - B. They have a thin layer of muscle to help pump blood to the veins.
 - C. They have thin, permeable walls to allow exchange of materials between tissue and blood.
 - D. They have a thin layer of elastic fibre to resist changes in blood pressure.

Turn over

27. Changes in membrane potential during nerve transmission along an axon involve the movement of sodium and potassium ions across the axon membrane.

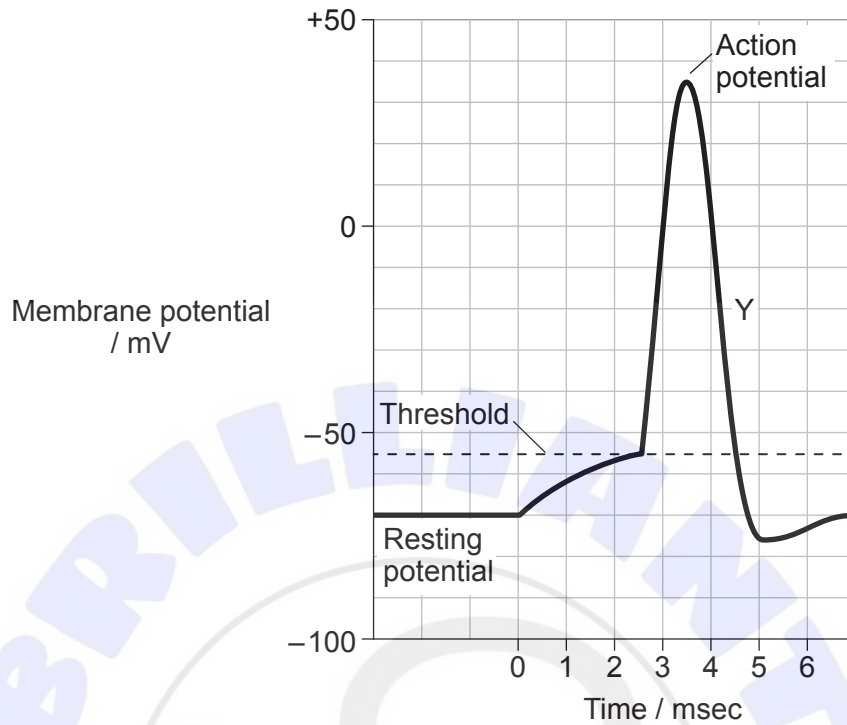

What explains the membrane potential at Y in the trace?

- A. Potassium channels open and allow potassium ions to move to the outside of the axon membrane.
 - B. Potassium channels allow potassium ions to enter the axon.
 - C. When the threshold voltage is reached, the sodium pump begins to pump sodium ions to the outside of the axon membrane.
 - D. Potassium and sodium channels are closed, so there is no movement of ions across the axon membrane.
28. What are functions of female reproductive hormones?
- A. Estrogen and progesterone promote the development of female reproductive organs in the embryo.
 - B. Follicle stimulating hormone (FSH) and luteinizing hormone (LH) are released by the ovary and combine to prevent ovulation.
 - C. Estrogen and progesterone are released by the pituitary and combine to prepare the uterus for pregnancy.
 - D. Follicle stimulating hormone (FSH) and luteinizing hormone (LH) promote the development of female reproductive organs in the embryo.

29. The diagrams show monomers formed by the digestion of macromolecules in the small intestine.

monomer 1

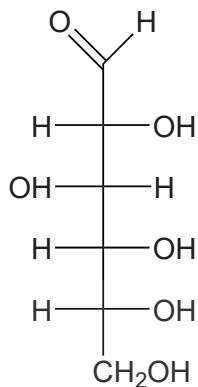

monomer 2

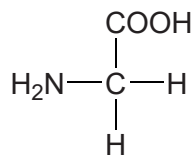

monomer 3

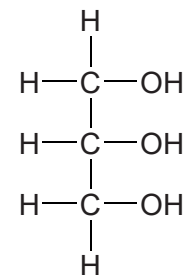

monomer 4

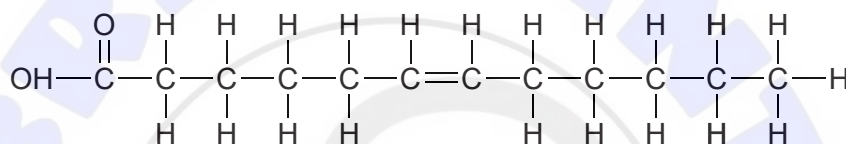

monomer 5

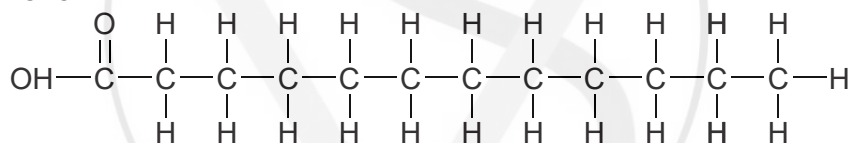

Which monomers could result from the digestion of an unsaturated fat?

- A. 1, 2 and 4 only
- B. 1 and 3 only
- C. 4 and 5 only
- D. 3, 4 and 5 only

Turn over

30. What is a function of the pancreas?
- A. To control the rate of metabolism by releasing thyroxine when metabolic rate is low
 - B. To release glucagon when blood glucose levels are low
 - C. To release insulin when blood glucose levels are low
 - D. To secrete an endopeptidase which lowers the blood glucose levels
-



Disclaimer:

Content used in IB assessments is taken from authentic, third-party sources. The views expressed within them belong to their individual authors and/or publishers and do not necessarily reflect the views of the IB.

References:

1. Fawcett, D.W., n.d. [*Micrograph of Myotis lucifugus*]. Available at: <https://www.sciencephoto.com/media/214818/view/pancreatic-cell-nucleus-tem> [Accessed 27 May 2024].
2. Summerer, M., Sonntag, B. and Sommaruga, R., 2007. An experimental test of the symbiosis specificity between the ciliate *Paramecium bursaria* and strains of the unicellular green alga *Chlorella*. *Environ Microbiol.* 9(8), 2117–22. [e-journal] Available at: <https://pubmed.ncbi.nlm.nih.gov/17635555/> [Accessed 11 April 2023]. Source adapted.
3. Ris, H., n.d. [*Dividing cell.*] [image online] Available at: <http://cellimagelibrary.org/images/35370> [Accessed 12 April 2023]. Source adapted.
13. Barahona Corrêa, B., Xavier, M. and Guimarães, J., 2006. Association of Huntington's disease and schizophrenia-like psychosis in a Huntington's disease pedigree. *Clinical Practice and Epidemiology in Mental Health* 2(1) [e-journal] Available at: <https://cpementalhealth.biomedcentral.com/articles/10.1186/1745-0179-2-1> [Accessed 11 April 2023]. Source adapted.
20. © University of California Museum of Paleontology. Available at: <https://ucmp.berkeley.edu/education/events/carlson2.html> [Accessed 13 April 2023]. Source adapted.
21. [*Visual connection*], n.d. [image online] Available at: <https://openstax.org/books/biology-2e/pages/18-3-reconnection-and-speciation-rates> [Accessed 16 May 2023]. Source adapted.
22. Porifera: dsabo, n.d. *Belize sponges*. [image online] Available at: <https://www.gettyimages.co.uk/detail/photo/belize-sponges-royalty-free-image/92252755> [Accessed 16 May 2023]. Source adapted.
Cnidaria: Alexisaj, n.d. *Beadlet anemone*. [image online] Available at: <https://www.gettyimages.co.uk/detail/photo/beadlet-anemone-royalty-free-image/1399597322> [Accessed 16 May 2023]. Source adapted.
Platyhelmintha: ifish, n.d. *Polyclad Flatworm Pseudobiceros flowersi on black sand of Lembeh Strait*. [image online] Available at: <https://www.gettyimages.co.uk/detail/photo/polyclad-flatworm-pseudobiceros-flowersi-on-black-royalty-free-image/92887669> [Accessed 16 May 2023]. Source adapted.
Annelida: Rosendo Serrano Valera, n.d. *A common earthworm goes underground*. [image online] Available at: <https://www.gettyimages.co.uk/detail/photo/a-common-earthworm-goes-underground-royalty-free-image/1485992647> [Accessed 16 May 2023]. Source adapted.
Mollusca: TheSP4N1SH, n.d. *Octopus vulgaris*. [image online] Available at: <https://www.gettyimages.co.uk/detail/photo/octopus-vulgaris-royalty-free-image/655094820> [Accessed 16 May 2023]. Source adapted.
Arthropoda: danikancil, n.d. *Spider walking in the web selective focus blur background*. [image online] Available at: <https://www.gettyimages.co.uk/detail/photo/spider-walking-in-the-web-selective-focus-blur-royalty-free-image/1446402485> [Accessed 16 May 2023]. Source adapted.
23. Biga, L.M., et al., n.d. *Anatomy and Physiology*. [online] Available at: <https://open.oregonstate.edu/aandp/chapter/19-3-cardiac-cycle/> [Accessed 13 April 2023]. Source adapted.
25. Huang, B., 2021. *Cellular & Molecular Immunology* 18, pp. 1823–25. [e-journal] Available at: <https://www.nature.com/articles/s41423-021-00714-8#Fig1> [Accessed 12 April 2023]. Source adapted.

All other texts, graphics and illustrations © International Baccalaureate Organization 2024