

© International Baccalaureate Organization 2024

All rights reserved. No part of this product may be reproduced in any form or by any electronic or mechanical means, including information storage and retrieval systems, without the prior written permission from the IB. Additionally, the license tied with this product prohibits use of any selected files or extracts from this product. Use by third parties, including but not limited to publishers, private teachers, tutoring or study services, preparatory schools, vendors operating curriculum mapping services or teacher resource digital platforms and app developers, whether fee-covered or not, is prohibited and is a criminal offense.

More information on how to request written permission in the form of a license can be obtained from <https://ibo.org/become-an-ib-school/ib-publishing/licensing/applying-for-a-license/>.

© Organisation du Baccalauréat International 2024

Tous droits réservés. Aucune partie de ce produit ne peut être reproduite sous quelque forme ni par quelque moyen que ce soit, électronique ou mécanique, y compris des systèmes de stockage et de récupération d'informations, sans l'autorisation écrite préalable de l'IB. De plus, la licence associée à ce produit interdit toute utilisation de tout fichier ou extrait sélectionné dans ce produit. L'utilisation par des tiers, y compris, sans toutefois s'y limiter, des éditeurs, des professeurs particuliers, des services de tutorat ou d'aide aux études, des établissements de préparation à l'enseignement supérieur, des fournisseurs de services de planification des programmes d'études, des gestionnaires de plateformes pédagogiques en ligne, et des développeurs d'applications, moyennant paiement ou non, est interdite et constitue une infraction pénale.

Pour plus d'informations sur la procédure à suivre pour obtenir une autorisation écrite sous la forme d'une licence, rendez-vous à l'adresse <https://ibo.org/become-an-ib-school/ib-publishing/licensing/applying-for-a-license/>.

© Organización del Bachillerato Internacional, 2024

Todos los derechos reservados. No se podrá reproducir ninguna parte de este producto de ninguna forma ni por ningún medio electrónico o mecánico, incluidos los sistemas de almacenamiento y recuperación de información, sin la previa autorización por escrito del IB. Además, la licencia vinculada a este producto prohíbe el uso de todo archivo o fragmento seleccionado de este producto. El uso por parte de terceros —lo que incluye, a título enunciativo, editoriales, profesores particulares, servicios de apoyo académico o ayuda para el estudio, colegios preparatorios, desarrolladores de aplicaciones y entidades que presten servicios de planificación curricular u ofrezcan recursos para docentes mediante plataformas digitales—, ya sea incluido en tasas o no, está prohibido y constituye un delito.

En este enlace encontrará más información sobre cómo solicitar una autorización por escrito en forma de licencia: <https://ibo.org/become-an-ib-school/ib-publishing/licensing/applying-for-a-license/>.



Physics
Higher level
Paper 2

26 April 2024

Zone A morning | **Zone B** morning | **Zone C** morning

Candidate session number

--	--	--	--	--	--	--	--	--	--

2 hours 15 minutes

Instructions to candidates

- Write your session number in the boxes above.
- Do not open this examination paper until instructed to do so.
- Answer all questions.
- Answers must be written within the answer boxes provided.
- A calculator is required for this paper.
- A clean copy of the **physics data booklet** is required for this paper.
- The maximum mark for this examination paper is **[90 marks]**.

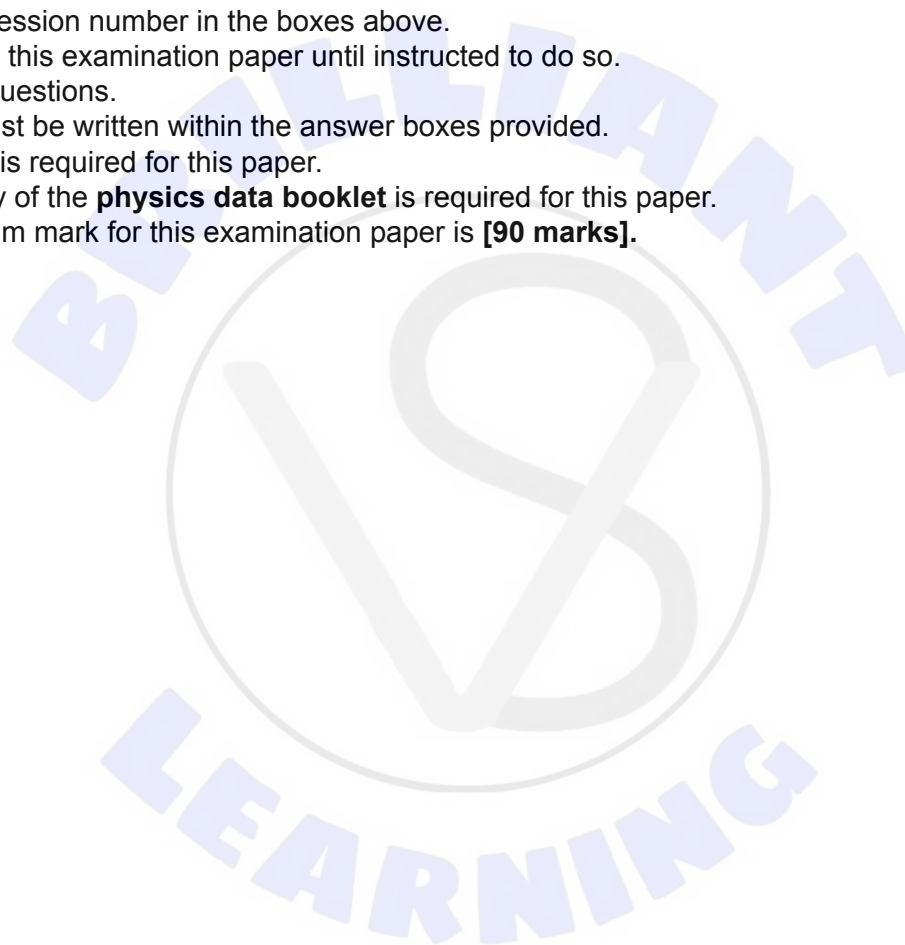



Please **do not** write on this page.

Answers written on this page
will not be marked.



Answer **all** questions. Answers must be written within the answer boxes provided.

1. A ball of mass 2.7 g is released from rest from a height of 28 m above horizontal ground.

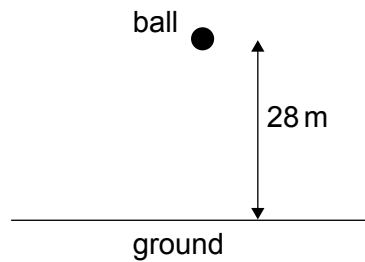

- (a) Show that in the absence of air resistance the ball impacts the ground with a speed of about 23 ms^{-1} . [1]

.....

.....

- (b) An air resistance force F acts on the ball. F can be modeled by $F = kv^2$ where v is the speed and k is a constant.
- (i) Determine the unit of k in terms of fundamental units. [2]

.....

.....

- (ii) Describe how the ball reaches terminal speed. [2]

.....

.....

.....

.....

(This question continues on the following page)



(Question 1 continued)

- (c) The graph shows the variation with time t of the speed v of the ball from the instant it is released until it impacts the ground.

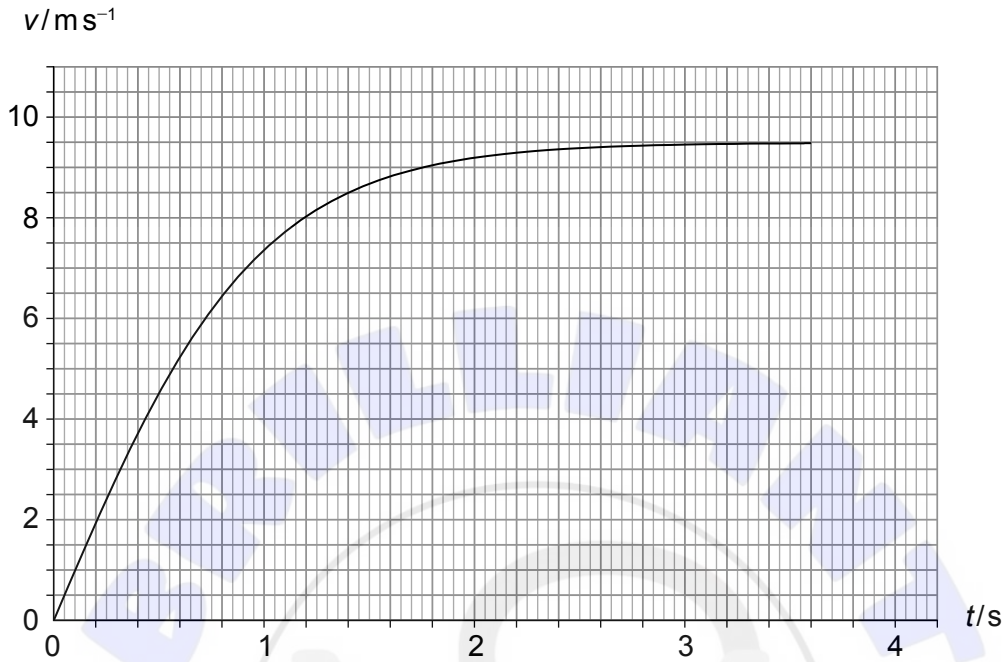

- (i) State the value of the area under the curve. [1]

.....

- (ii) Determine k . [2]

.....
.....
.....
.....

(This question continues on the following page)



(Question 1 continued)

- (iii) On the axes below, draw a graph to show the variation of the magnitude of the **resultant** force, F , on the ball with time t . No numbers are required on the axes. [1]

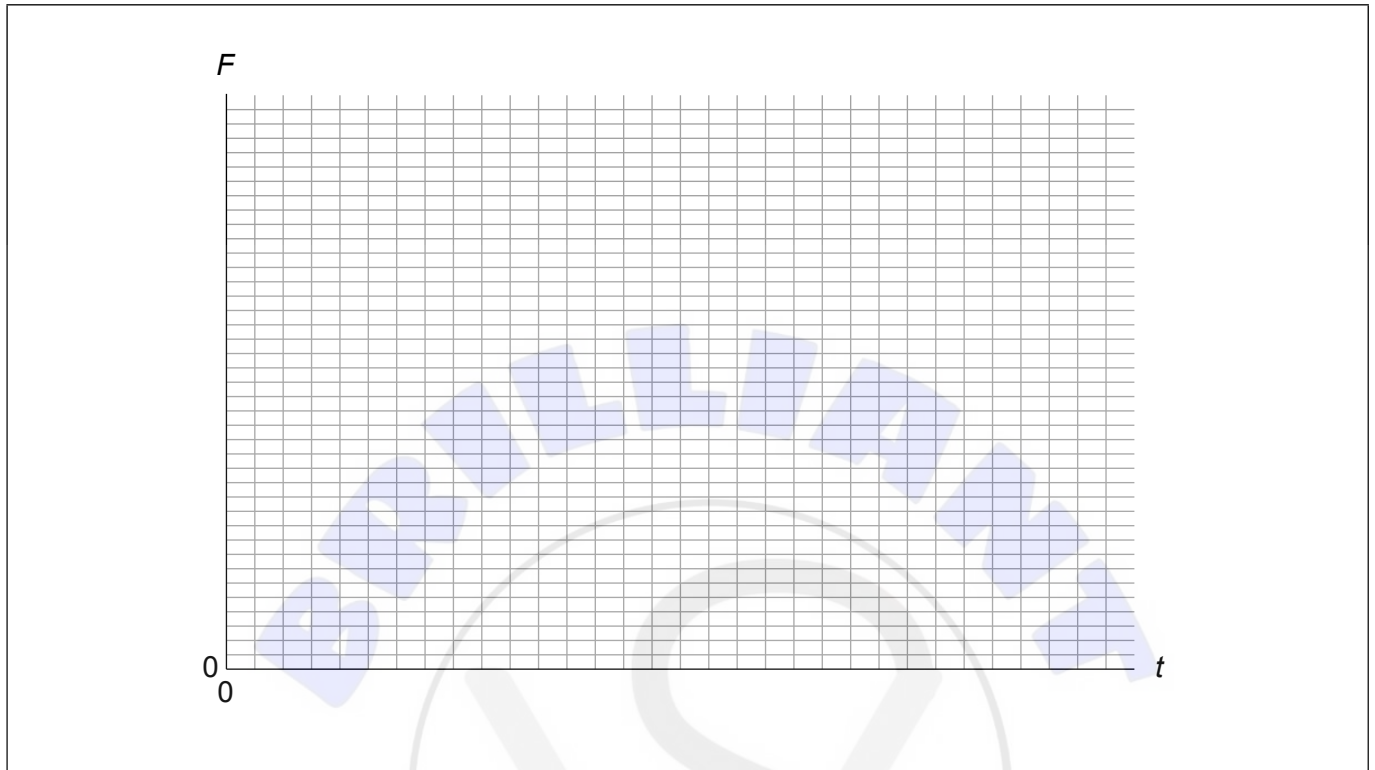

- (iv) Calculate the average power dissipated by the air resistance force. [3]

.....

.....

.....

.....

- (d) The ball rebounds from the ground with speed 7.8 m s^{-1} . The ball is in contact with the ground for a time T . The average **resultant** force on the ball during this time is 1.1 N .

Determine T . [2]

.....

.....

.....



2. Crushed ice of mass 35 g at temperature -10°C is placed in a warm room. The graph shows the variation of the temperature T of the ice with time t .

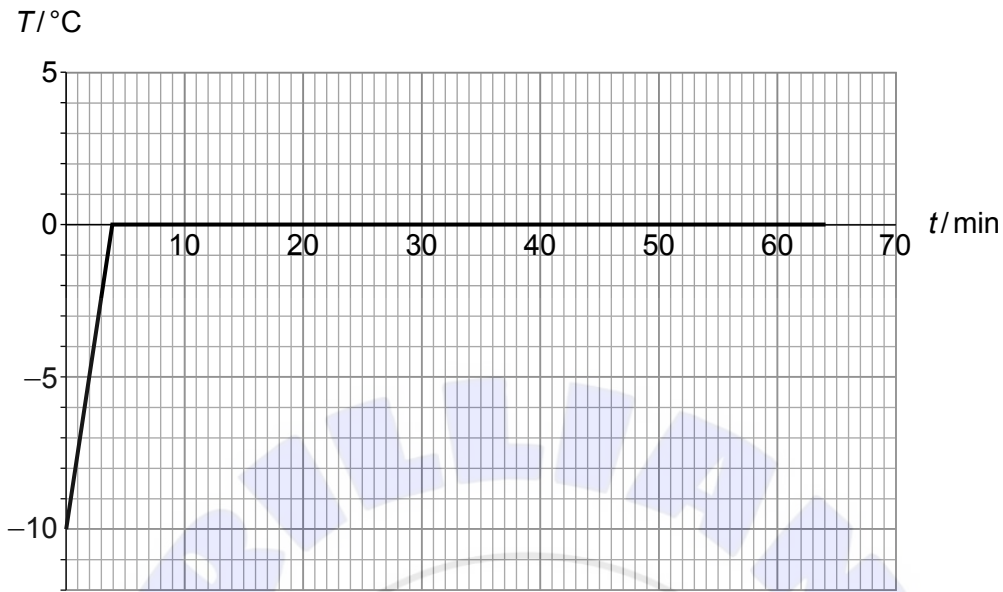

The specific heat capacity of ice is $2100\text{ J kg}^{-1}\text{ K}^{-1}$.

- (a) (i) Show that the average rate at which thermal energy is being transferred into the ice is about 3 W. [2]

.....

.....

.....

- (ii) Estimate the specific latent heat of fusion of ice. [2]

.....

.....

.....

(This question continues on the following page)



(Question 2 continued)

- (b) Between 4 minutes and 64 minutes solid ice and liquid water coexist at 0 °C. Compare and contrast, during this time, the internal energy of solid ice to that of an equal mass of liquid water. [2]

.....

.....

.....

.....



3. (a) Outline what is meant by a travelling wave. [2]

.....

.....

.....

.....

(b) A loudspeaker emits sound of frequency 210 Hz into a pipe with one open and one closed end. The diagram shows a representation of the standing wave established in the pipe.

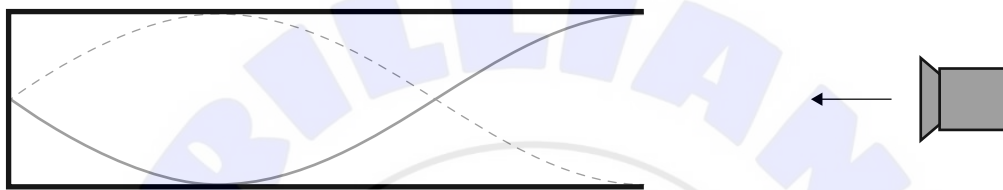

The length of the pipe is 1.20 m.

(i) Outline how the standing wave is formed in the pipe. [2]

.....

.....

.....

.....

(ii) Determine the wavelength of the wave. [1]

.....

.....

.....

(This question continues on the following page)



(Question 3 continued)

- (iii) Calculate the speed of sound in the pipe stating the answer to an appropriate number of significant figures. [2]

.....

.....

.....

.....

- (c) The solid line represents the standing wave at time t and the dotted line represents the standing wave at an instant later. The dot is the **equilibrium** position of a particle P in the pipe. The up arrow indicates displacements to the right and the down arrow displacements to the left.

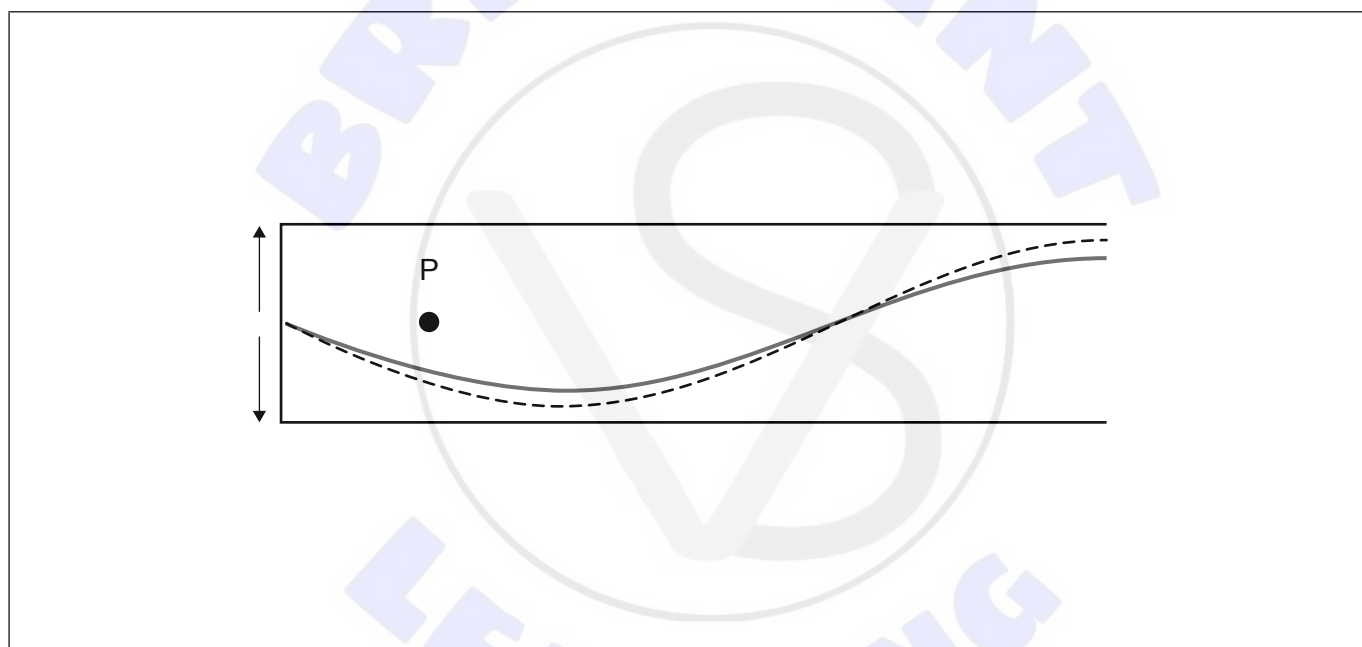

On the diagram, draw

- (i) a dot to indicate the approximate position of P at time t , [1]
- (ii) an arrow to indicate the velocity of P at time t . [1]

(This question continues on page 11)





Please **do not** write on this page.

Answers written on this page
will not be marked.



(Question 3 continued)

- (d) The amplitude of oscillations of the standing wave in (b) is 4.2 mm. The mass of particle P in (c) is 1.8×10^{-6} kg.

Calculate

- (i) the total energy of P, [2]

.....

.....

.....

.....

- (ii) the displacement of P, when its kinetic energy is equal to its potential energy. [2]

.....

.....

.....

.....

- (e) The frequency of sound is reduced to 140 Hz. Explain why a standing wave will not be formed in the pipe. [2]

.....

.....

.....

.....



4. (a) The diagram shows a junction in a circuit.

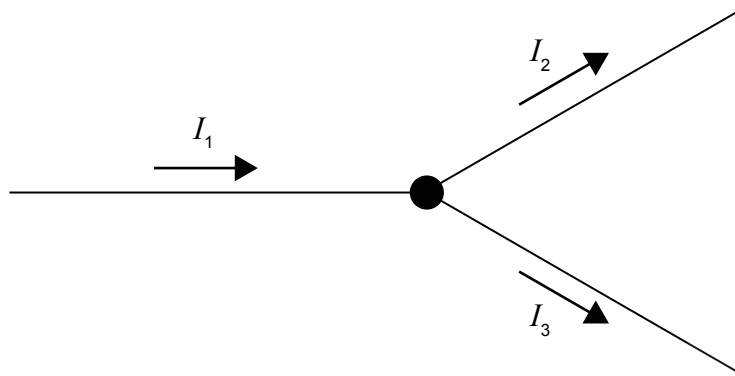

The currents in the three wires are related by $I_1 = I_2 + I_3$.

State the fundamental law of Physics from which this relation is derived.

[1]

.....

.....

- (b) A cell of emf 1.50 V and internal resistance r is connected to a resistor of resistance 5.00Ω and an ideal voltmeter V.

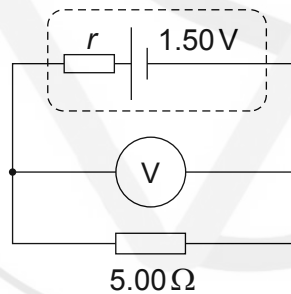

The reading of the voltmeter is 1.20 V.

- (i) Determine the internal resistance r of the cell.

[2]

.....

.....

.....

.....

(This question continues on the following page)



(Question 4 continued)

(ii) A second $5.00\ \Omega$ resistor is connected in parallel to the first resistor.

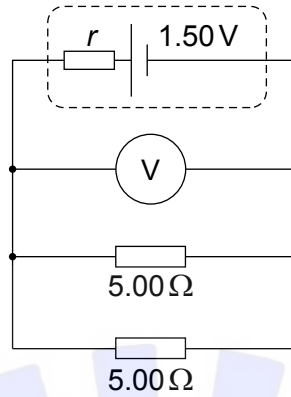

State and explain the change, if any, in the voltmeter reading without further calculation.

[2]

.....

.....

.....

.....

(This question continues on page 15)

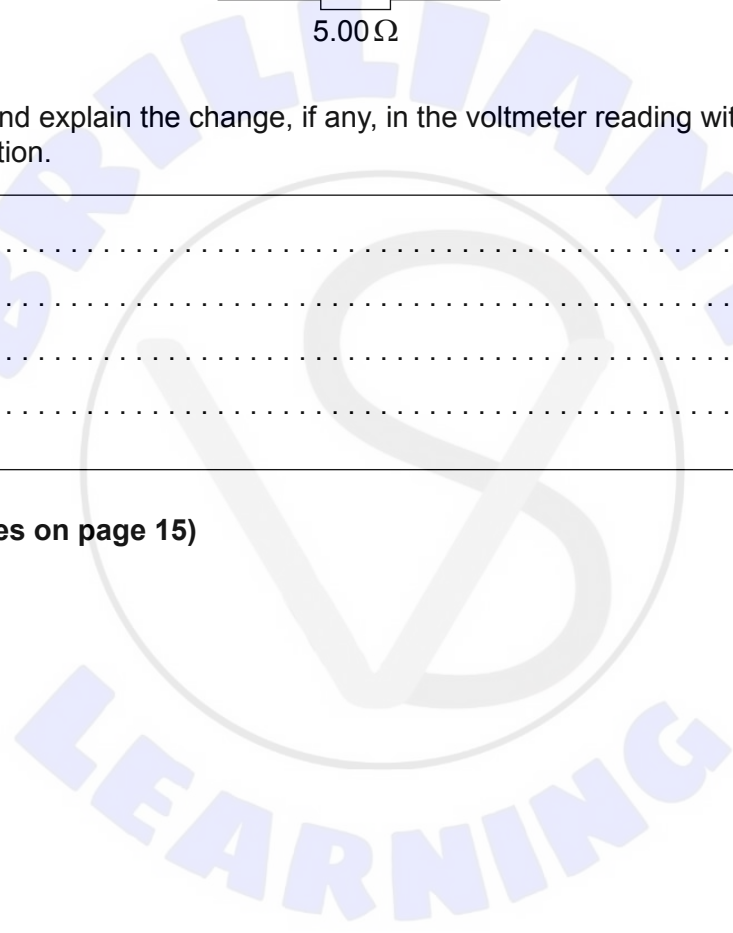



Please **do not** write on this page.

Answers written on this page
will not be marked.



(Question 4 continued)

- (c) A proton moves on a circular path in a region of uniform magnetic field of magnetic flux density B that is directed into the plane of the page.

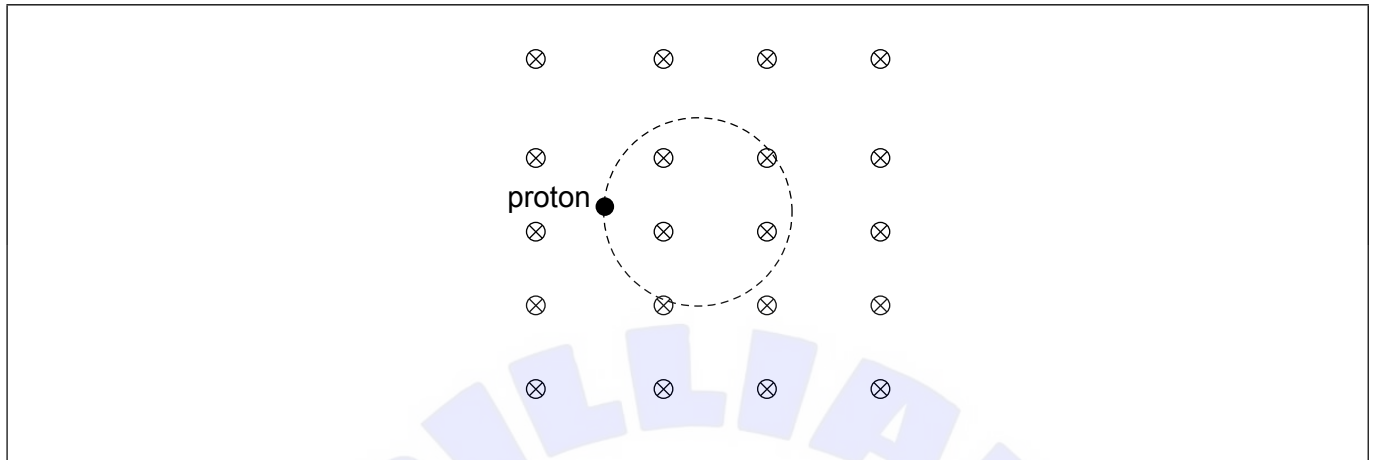

- (i) On the diagram, draw an arrow to indicate the velocity of the proton at the position shown. [1]
- (ii) Show that the frequency of revolution of the proton is given by $f = \frac{eB}{2\pi m_p}$. [3]

.....

.....

.....

.....

.....

.....

- (iii) The magnitude of B is 2.5 T. Calculate the frequency of revolution of the proton. [1]

.....

.....



5. A probe of mass m has landed on the equator of a rotating asteroid of mass M and radius R .

diagram not to scale

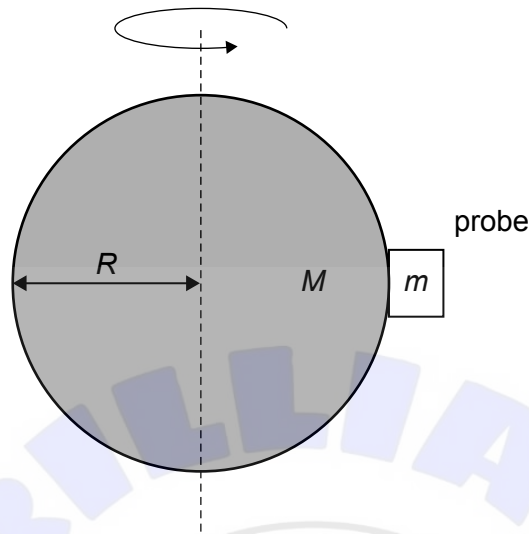

The asteroid rotates with angular speed ω .

- (a) By drawing a free-body diagram for the probe, show that the normal force, N , on the probe from the asteroid is given by $N = m\left(\frac{GM}{R^2} - \omega^2 R\right)$. [2]

A large empty rectangular box intended for drawing a free-body diagram for the probe. A faint watermark "BRILLIANT LEARNING" is visible in the background. At the bottom center of the box, there is a small diagram of the probe labeled "probe" and "m".

Two horizontal dotted lines provided for writing the solution to part (a).

(This question continues on the following page)



(Question 5 continued)

- (b) Deduce that the probe will remain on the asteroid surface only if $\omega \leq \sqrt{\frac{GM}{R^3}}$. [1]

.....
.....

- (c) Another probe orbits the Sun.

- (i) The distance between the probe and the Sun is 4 times the distance between the Earth and the Sun. Show that the intensity of the solar radiation at the surface of the probe is 85 W m^{-2} . [2]

.....
.....
.....
.....

- (ii) Estimate the equilibrium temperature of the probe assuming it behaves as a black body. [2]

.....
.....
.....
.....



6. (a) Quarks are elementary particles.

(i) State what is meant by an elementary particle. [1]

.....
.....

(ii) List the fundamental forces that act on quarks. [1]

.....
.....

(iii) The lambda baryon (Λ^0) has quark content uds . It decays according to the reaction $\Lambda^0 \rightarrow p + \pi^-$. The quark content of the pion is $\bar{u}d$.

State and explain which fundamental interaction is responsible for this decay. [2]

.....
.....
.....
.....

(This question continues on the following page)

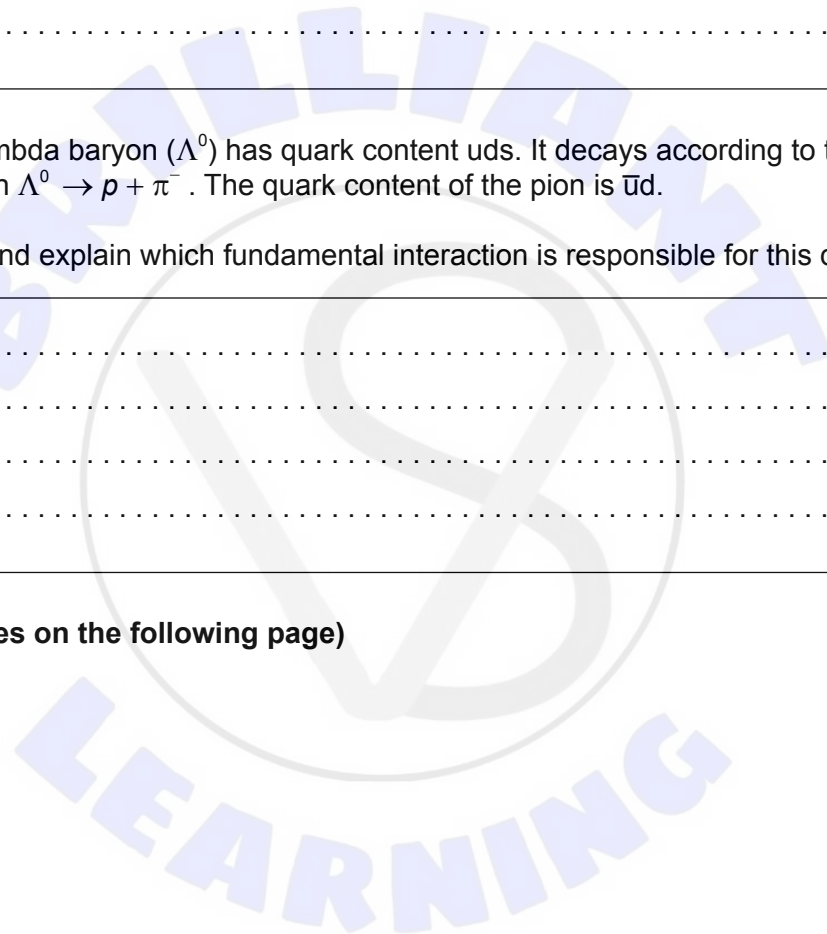

(Question 6 continued)

- (b) (i) By reference to the concept of binding energy, explain why the combined mass of the nucleons of a nucleus is greater than the mass of the nucleus. [2]

.....

.....

.....

.....

- (ii) The following binding energies per nucleon are available:

Th: 7.645074 MeV
Ra: 7.679917 MeV
He: 7.073915 MeV

Determine the energy released in the decay ${}_{90}^{228}\text{Th} \rightarrow {}_{88}^{224}\text{Ra} + {}_2^4\text{He}$. [2]

.....

.....

.....

.....

- (iii) It is observed that, sometimes, the alpha decay of thorium is accompanied by gamma ray emission. Suggest an explanation for this observation. [2]

.....

.....

.....

.....



7. Light of wavelength λ diffracts at a single rectangular slit of opening b . The diagram shows two rays of light leaving the top and middle of the slit. The rays come from the same wavefront. The angle of diffraction is θ . For small angles the approximation $\sin \theta \approx \theta$ may be used.

diagram not to scale

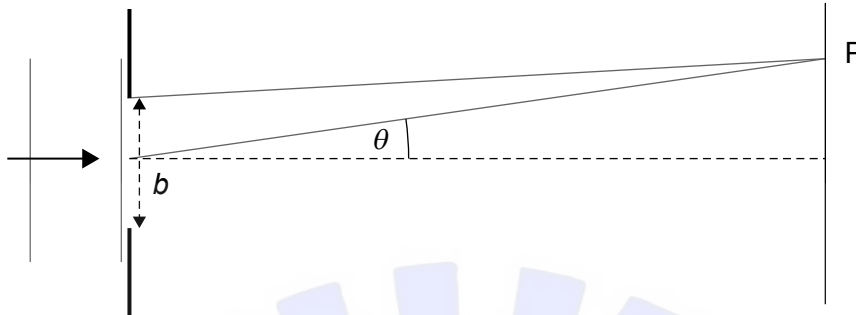

The rays meet at point P on a screen a very large distance from the slit.

- (a) (i) Show that the phase difference between the two rays at P is $\frac{\pi b \theta}{\lambda}$. [2]

.....

.....

- (ii) The two rays interfere destructively at P to form the first minimum of the single slit diffraction pattern. Explain why $\theta = \frac{\lambda}{b}$. [1]

.....

.....

(This question continues on the following page)



(Question 7 continued)

(b) The James Webb Space Telescope (JWST) has an effective diameter of 6.5 m.

(i) Calculate the smallest linear size at a distance of 13.6 billion light years (1.3×10^{26} m) that can be resolved by the JWST when it operates at a wavelength of 1200 nm. [2]

.....
.....
.....
.....

(ii) The JWST can also operate at wavelengths longer than 1200 nm. Suggest whether the resolution of the telescope is improved at the longer wavelengths. [1]

.....
.....

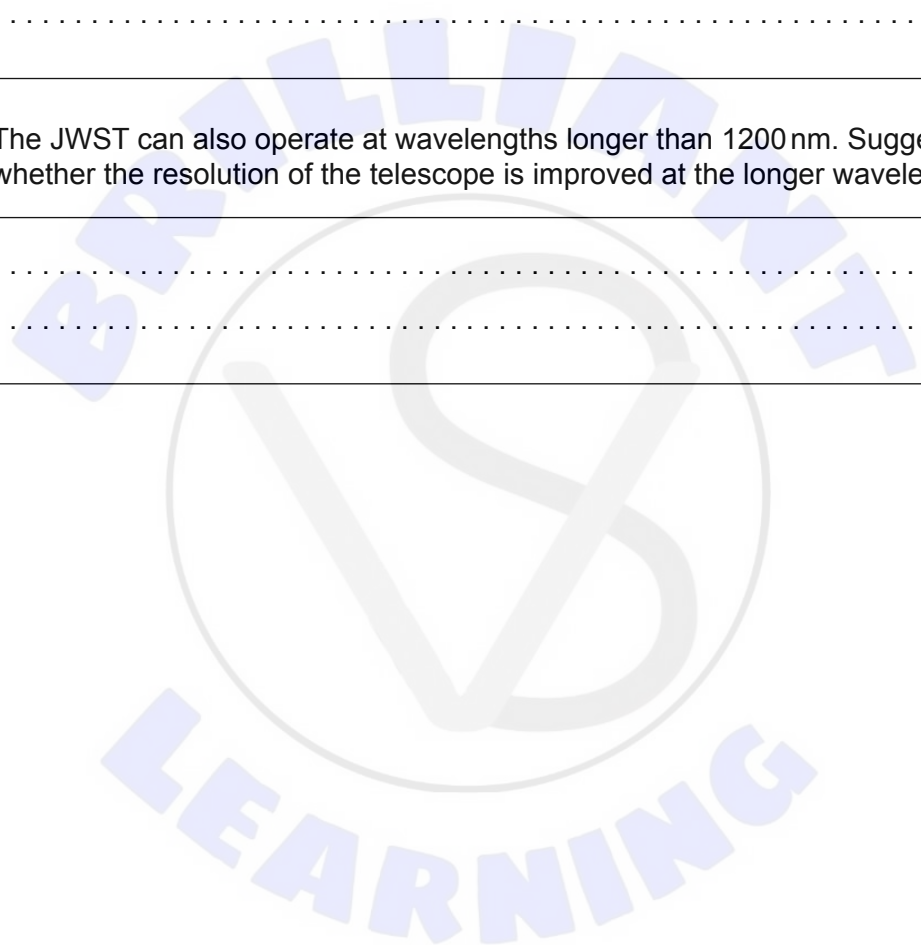



Please **do not** write on this page.

Answers written on this page
will not be marked.



8. A uniform, spherical planet P has mass M and radius R .

(a) A projectile of mass m is launched with kinetic energy $\frac{2GMm}{3R}$ from the surface of P.

diagram not to scale

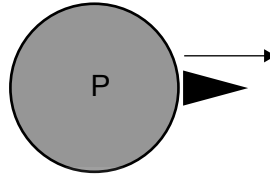

Determine whether the projectile will escape the gravitational field of P.

[2]

.....

.....

.....

.....

(This question continues on the following page)

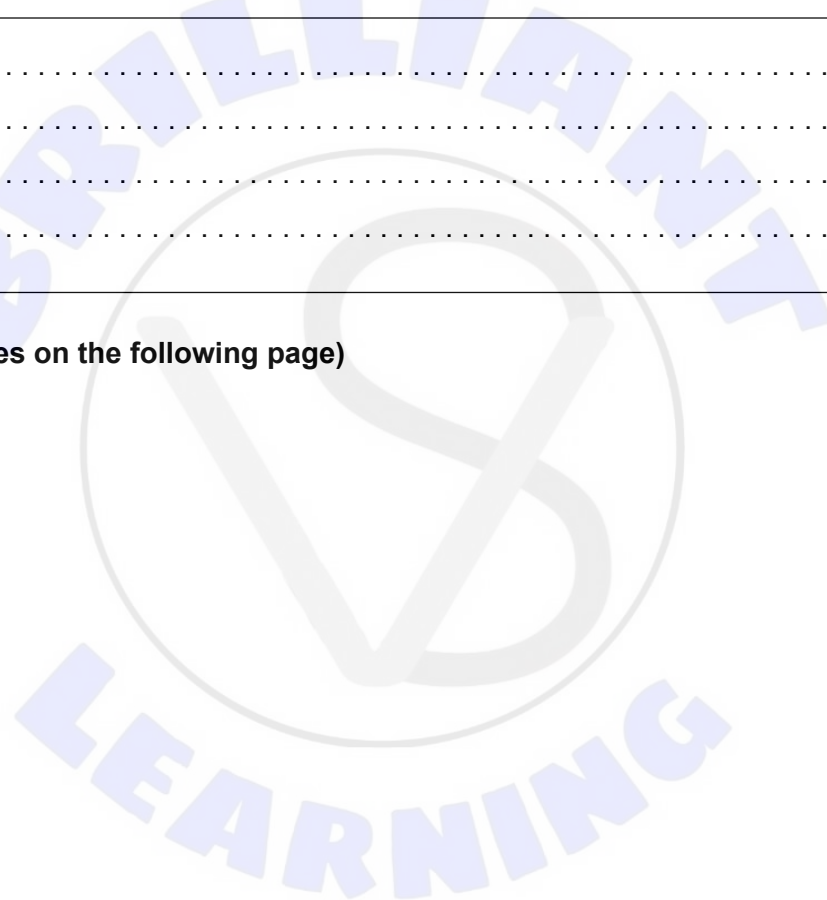

(Question 8 continued)

- (b) The surface of P is an equipotential surface E_0 . The dotted circle labeled E_1 is an equipotential line at a distance $\frac{3R}{2}$ from the centre of P. The potential difference between E_1 and E_0 is $2.2 \times 10^6 \text{ J kg}^{-1}$.

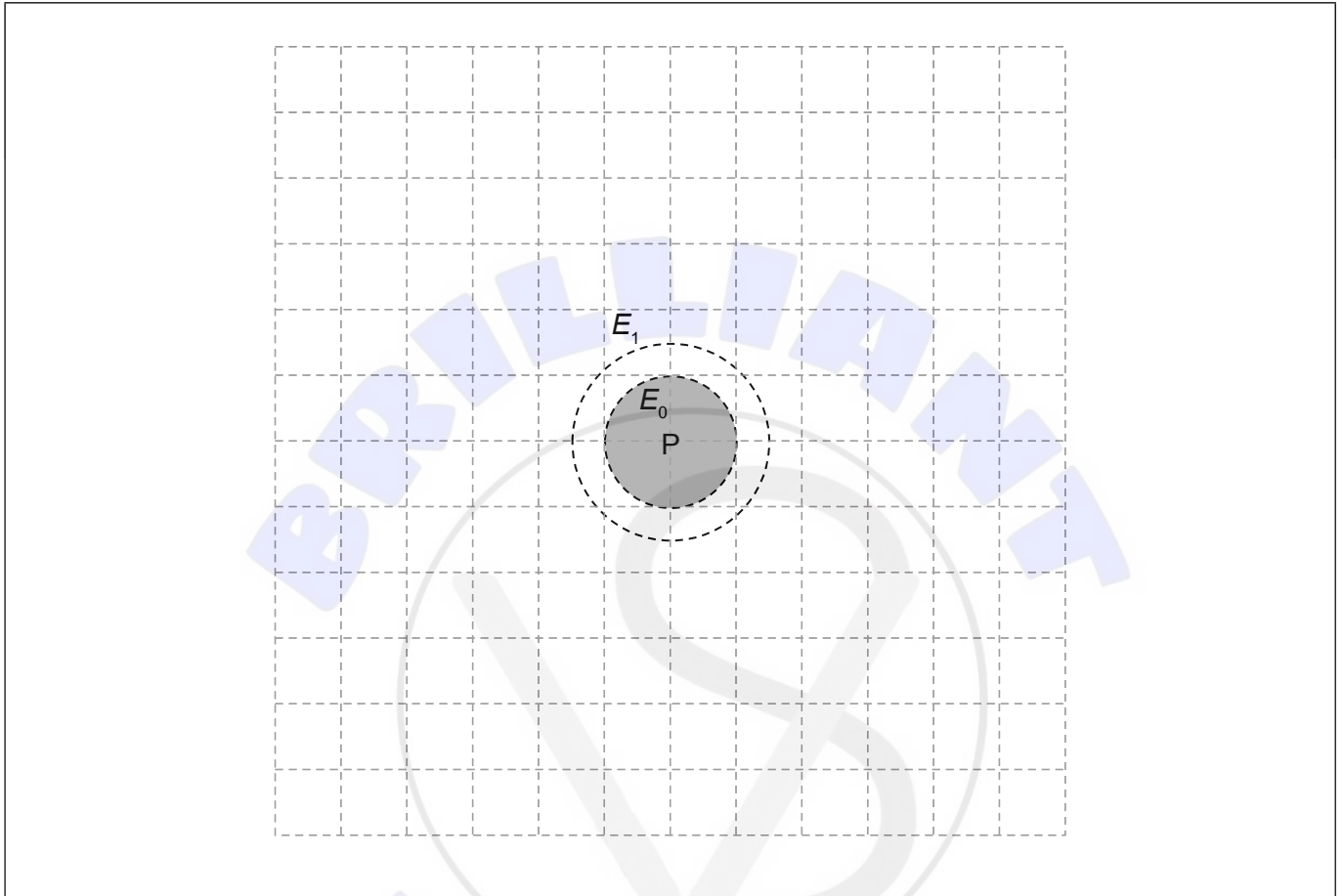

- (i) The radius R of P is $8.5 \times 10^6 \text{ m}$.

Estimate the magnitude of the gravitational field strength between E_1 and E_0 .

[2]

.....

.....

.....

.....

(This question continues on the following page)



(Question 8 continued)

- (ii) E_2 is an equipotential line such that the potential difference between E_2 and E_1 is also $2.2 \times 10^6 \text{ J kg}^{-1}$.

Draw the equipotential line E_2 on the diagram.

[2]

.....

.....





Please **do not** write on this page.

Answers written on this page
will not be marked.



9. (a) A conducting rod of length L is moved with speed v at right angles to a uniform magnetic field of flux density B . The field is directed into the plane of the page.

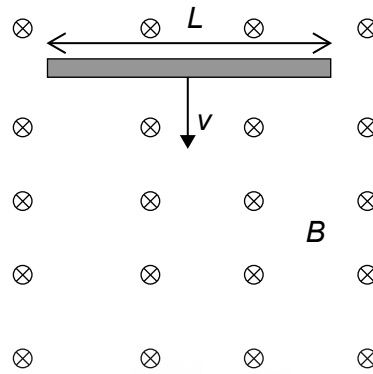

- (i) Show, using Faraday's law or otherwise, that the potential difference, V , established between the ends of the rod is $V = vBL$. [3]

.....

.....

.....

.....

- (ii) Identify the end of the rod that becomes negatively charged. [1]

.....

.....

.....

.....

(This question continues on the following page)



(Question 9 continued)

- (b) A coil is rotating in a region of magnetic field with angular speed 12.56 rad s^{-1} . At $t = 0$, the field is parallel to the surface of the coil.

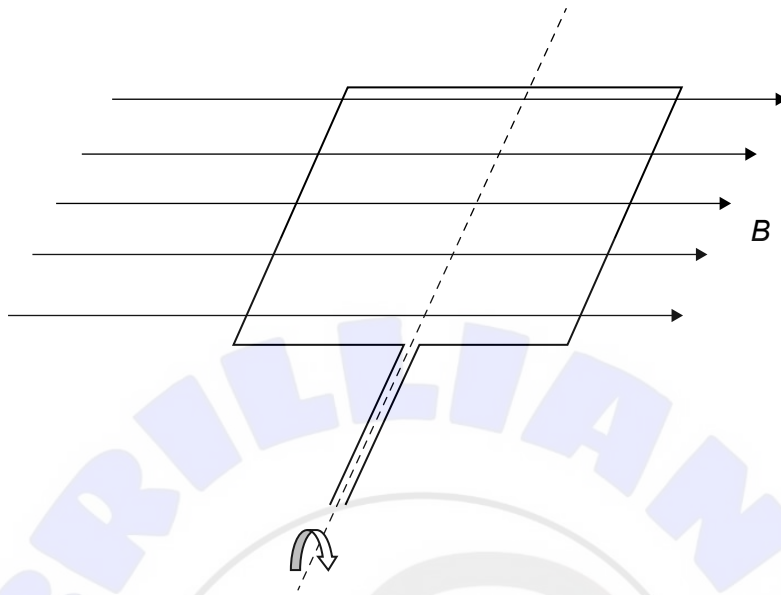

- (i) State the magnetic flux linkage through the coil at $t = 0$.

[1]

.....

.....

(This question continues on the following page)



(Question 9 continued)

- (ii) Draw, on the axes, a graph to show the variation with time of the induced emf in the loop. (No numbers are required on the vertical axis.)

[2]

.....

.....

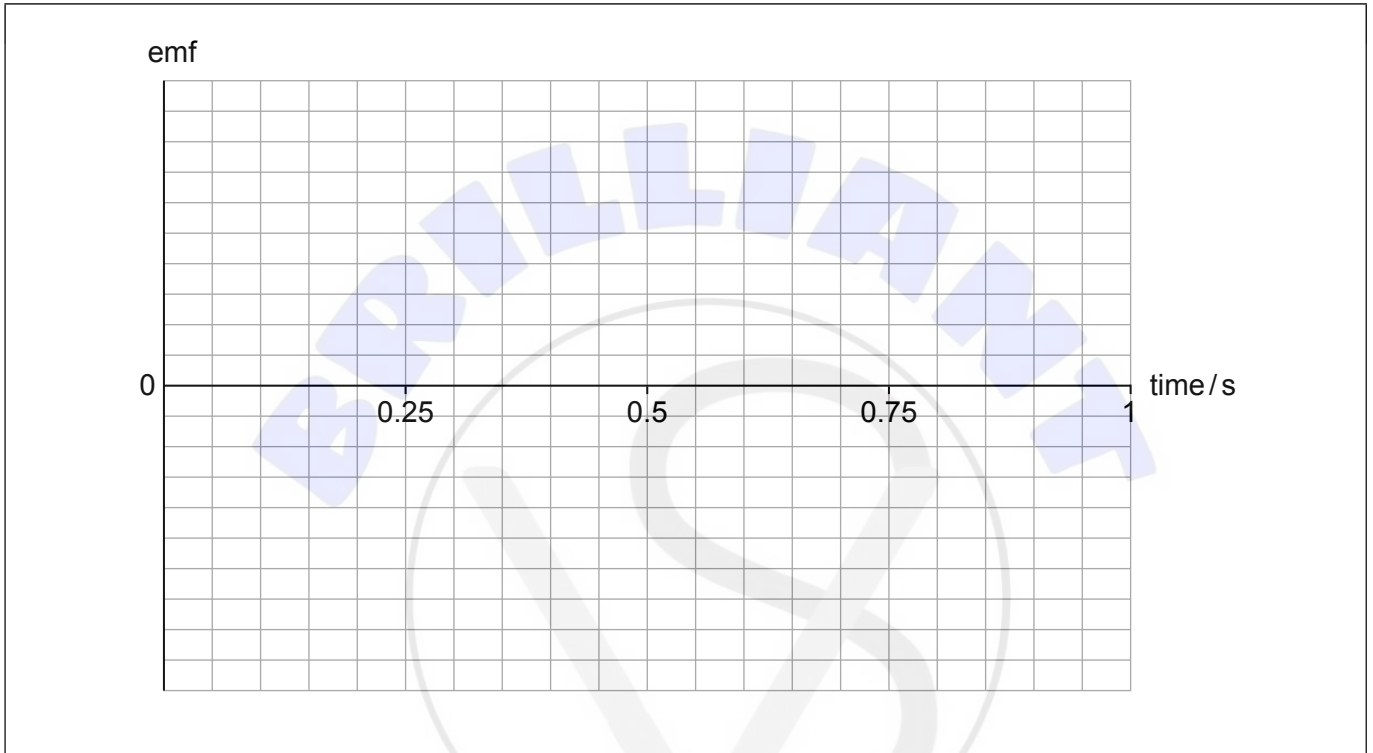

- (c) A capacitor is connected to a cell. The switch S is closed and the capacitor becomes fully charged.

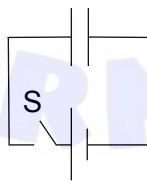

A dielectric is then inserted in between the plates of the capacitor. Suggest what, if anything, will happen to the charge on one plate of the capacitor.

[2]

.....

.....

.....

.....



10. (a) (i) In the Bohr model for the hydrogen atom orbital angular momentum is quantized ($mvr = n\frac{h}{2\pi}$). Outline the effect this has on the electron energy. [1]

.....
.....

- (ii) For the hydrogen atom, the orbit radius of the electron in the $n = 2$ state is four times larger than the orbit radius in the $n = 1$ state. Determine the ratio $\frac{v_2}{v_1}$ of the electron speed in the $n = 2$ state to the speed in the $n = 1$. [2]

.....
.....
.....
.....

- (b) Compare and contrast the Bohr prediction for the radius of an electron orbit in hydrogen to that of the description of the electron in terms of a wave function. [2]

.....
.....
.....
.....

- (c) Determine, using the uncertainty principle, the minimum kinetic energy of a neutron inside a nucleus of radius 3×10^{-15} m. [2]

.....
.....
.....
.....





Please **do not** write on this page.

Answers written on this page
will not be marked.



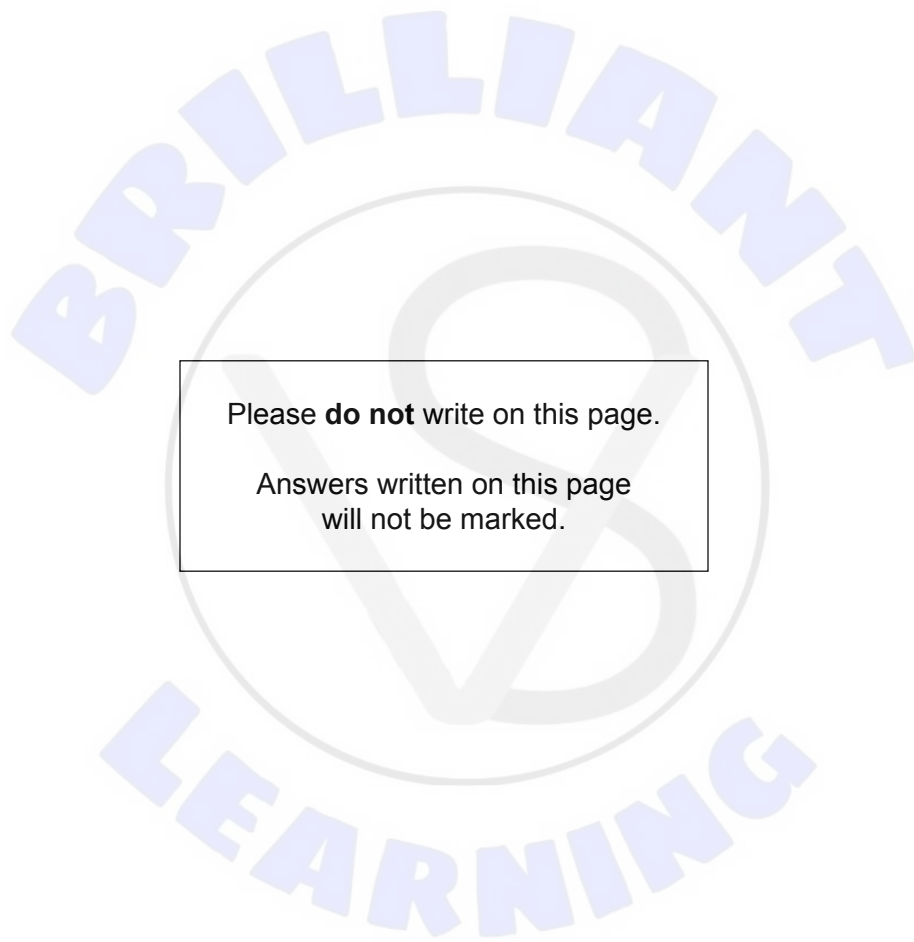

Please **do not** write on this page.

Answers written on this page
will not be marked.

