

© International Baccalaureate Organization 2024

All rights reserved. No part of this product may be reproduced in any form or by any electronic or mechanical means, including information storage and retrieval systems, without the prior written permission from the IB. Additionally, the license tied with this product prohibits use of any selected files or extracts from this product. Use by third parties, including but not limited to publishers, private teachers, tutoring or study services, preparatory schools, vendors operating curriculum mapping services or teacher resource digital platforms and app developers, whether fee-covered or not, is prohibited and is a criminal offense.

More information on how to request written permission in the form of a license can be obtained from <https://ibo.org/become-an-ib-school/ib-publishing/licensing/applying-for-a-license/>.

© Organisation du Baccalauréat International 2024

Tous droits réservés. Aucune partie de ce produit ne peut être reproduite sous quelque forme ni par quelque moyen que ce soit, électronique ou mécanique, y compris des systèmes de stockage et de récupération d'informations, sans l'autorisation écrite préalable de l'IB. De plus, la licence associée à ce produit interdit toute utilisation de tout fichier ou extrait sélectionné dans ce produit. L'utilisation par des tiers, y compris, sans toutefois s'y limiter, des éditeurs, des professeurs particuliers, des services de tutorat ou d'aide aux études, des établissements de préparation à l'enseignement supérieur, des fournisseurs de services de planification des programmes d'études, des gestionnaires de plateformes pédagogiques en ligne, et des développeurs d'applications, moyennant paiement ou non, est interdite et constitue une infraction pénale.

Pour plus d'informations sur la procédure à suivre pour obtenir une autorisation écrite sous la forme d'une licence, rendez-vous à l'adresse <https://ibo.org/become-an-ib-school/ib-publishing/licensing/applying-for-a-license/>.

© Organización del Bachillerato Internacional, 2024

Todos los derechos reservados. No se podrá reproducir ninguna parte de este producto de ninguna forma ni por ningún medio electrónico o mecánico, incluidos los sistemas de almacenamiento y recuperación de información, sin la previa autorización por escrito del IB. Además, la licencia vinculada a este producto prohíbe el uso de todo archivo o fragmento seleccionado de este producto. El uso por parte de terceros —lo que incluye, a título enunciativo, editoriales, profesores particulares, servicios de apoyo académico o ayuda para el estudio, colegios preparatorios, desarrolladores de aplicaciones y entidades que presten servicios de planificación curricular u ofrezcan recursos para docentes mediante plataformas digitales—, ya sea incluido en tasas o no, está prohibido y constituye un delito.

En este enlace encontrará más información sobre cómo solicitar una autorización por escrito en forma de licencia: <https://ibo.org/become-an-ib-school/ib-publishing/licensing/applying-for-a-license/>.

Physics
Standard level
Paper 2

26 April 2024

Zone A morning | **Zone B** morning | **Zone C** morning

Candidate session number

1 hour 15 minutes

--	--	--	--	--	--	--	--	--	--

Instructions to candidates

- Write your session number in the boxes above.
- Do not open this examination paper until instructed to do so.
- Answer all questions.
- Answers must be written within the answer boxes provided.
- A calculator is required for this paper.
- A clean copy of the **physics data booklet** is required for this paper.
- The maximum mark for this examination paper is **[50 marks]**.

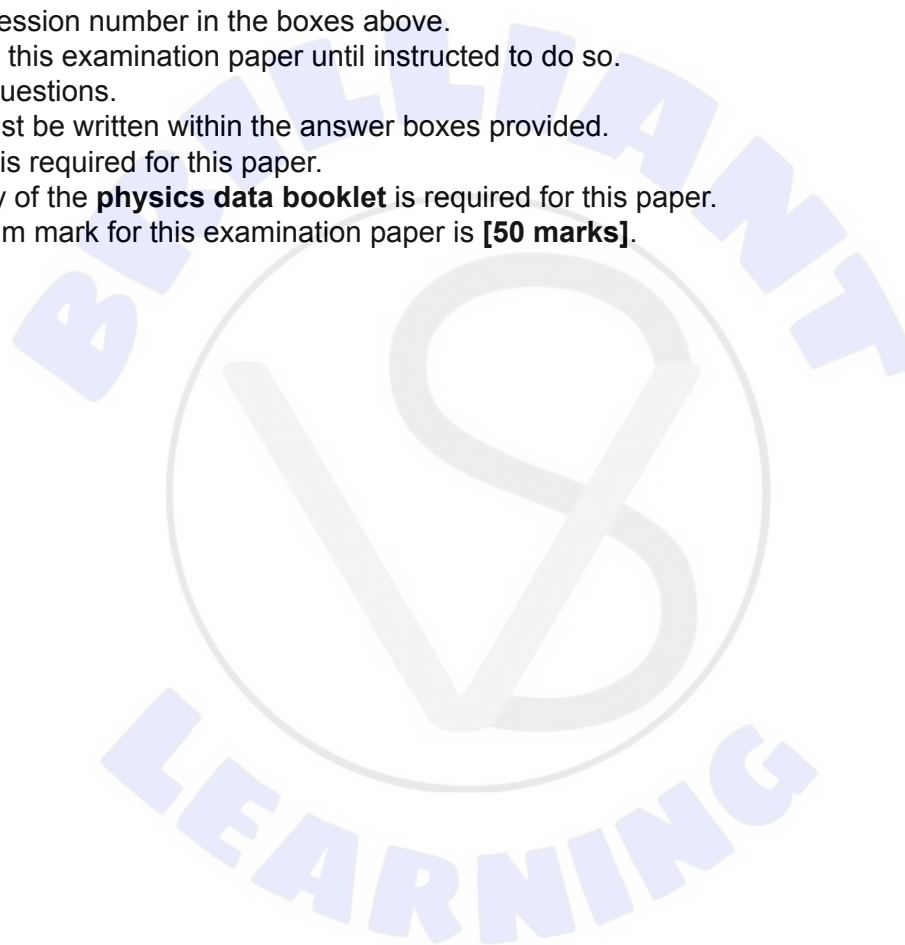

Answer **all** questions. Answers must be written within the answer boxes provided.

1. A stationary ball is hanging from a light string. A pellet from an air rifle is travelling horizontally and becomes embedded in the ball. The velocity of the pellet when it strikes the ball is 160 ms^{-1} .



The following data are given.

Mass of the ball = 250 g

Mass of the pellet = 2.0 g

- (a) Calculate the speed of the ball and the pellet immediately after the impact. [2]

.....
.....
.....
.....

- (b) Suggest why the combined kinetic energy of the ball and the pellet after the impact is less than the initial kinetic energy of the pellet. [2]

.....
.....
.....
.....

(This question continues on the following page)



(Question 1 continued)

The ball with the embedded pellet rises to a maximum vertical height h .

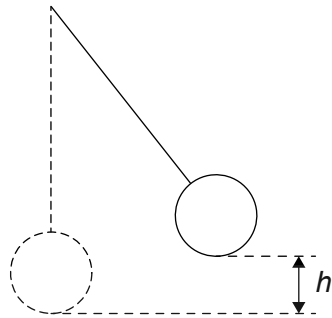

(c) Draw and label the free-body diagram for the ball at height h .

[2]

A rectangular box for drawing a free-body diagram. A dashed line labeled "string direction" points from a central dot labeled "ball and pellet" towards the top-left corner of the box.

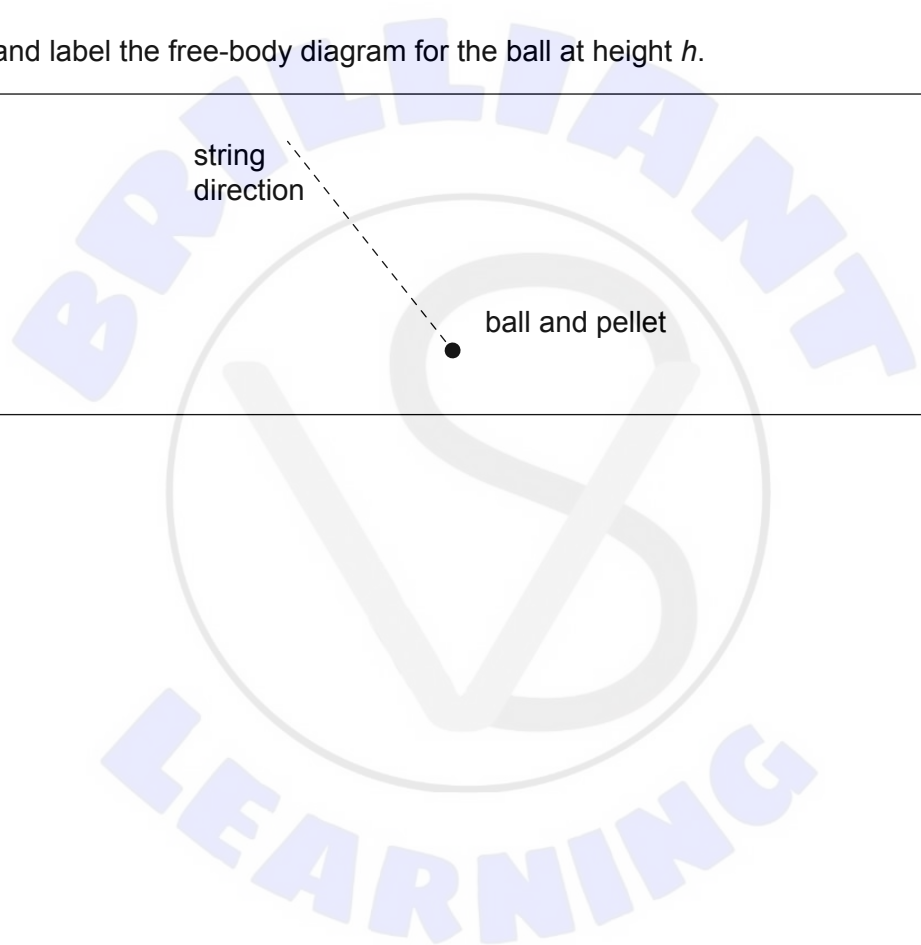



Please **do not** write on this page.

Answers written on this page
will not be marked.



2. A student throws a ball towards a wall. The ball is released from a point 1.8 m above the ground and 8.0 m from the wall. The initial velocity of the ball makes an angle of 48° with the horizontal. Air resistance is negligible.

The diagram shows the initial path of the ball. P is a point on the path.

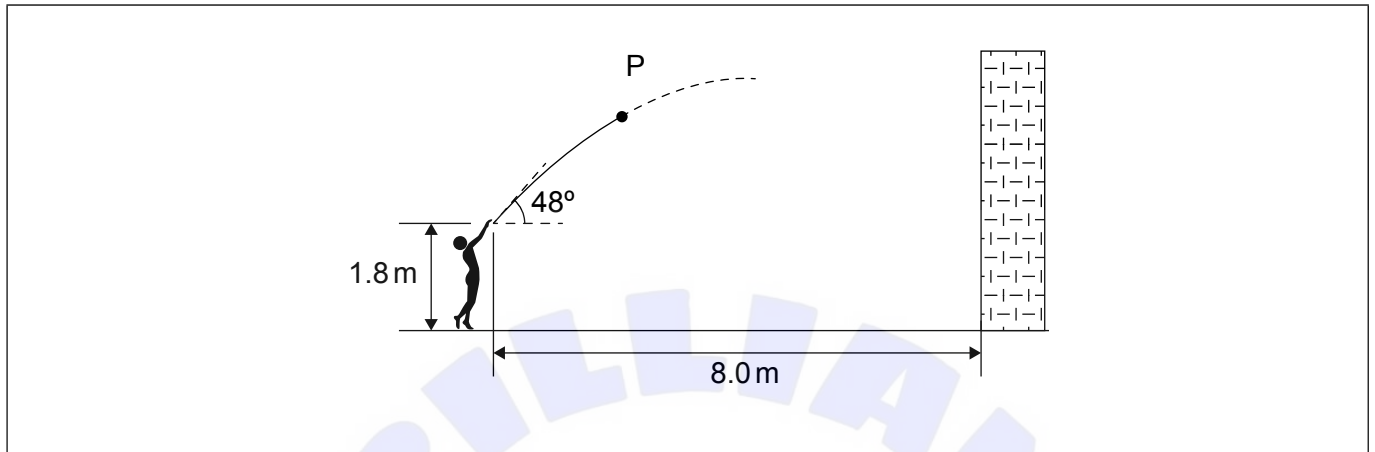

- (a) Draw, on the diagram, an arrow to show
- (i) the velocity of the ball at P. Label this arrow v . [1]
 - (ii) the acceleration of the ball at P. Label this arrow a . [1]

The ball takes 1.3 s to reach the wall. The initial speed of the ball is 9.2 ms^{-1} .

- (b) Determine the height above the ground at which the ball hits the wall. [3]

.....

.....

.....

.....

.....

.....



3. A fixed quantity of 4.5×10^{-3} mol of air is compressed at a constant temperature. The graph shows the variation of pressure p with volume V of the air.

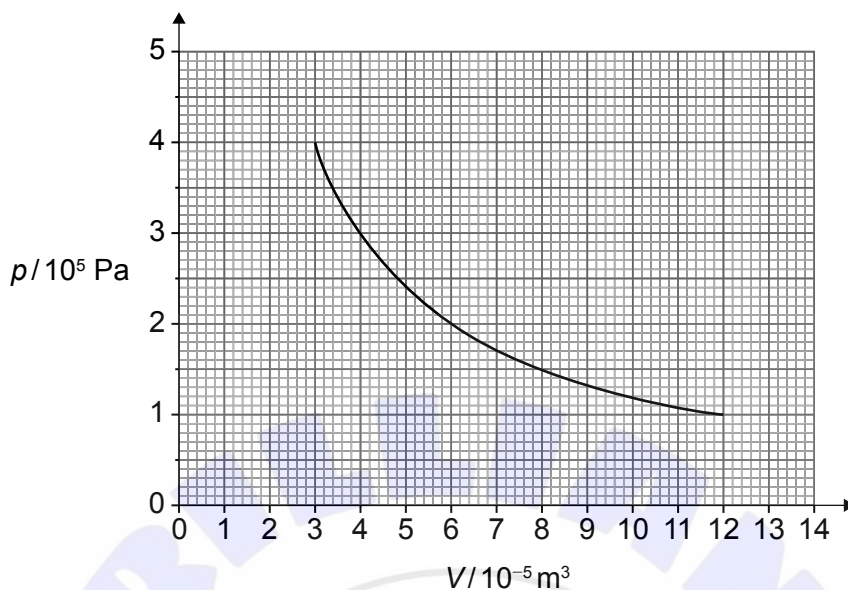

- (a) Suggest whether the air behaves as an ideal gas during this change. [2]

.....

.....

.....

.....

.....

.....

- (b) Calculate the temperature of the air. [2]

.....

.....

.....

.....

(This question continues on the following page)



(Question 3 continued)

- (c) Outline how the kinetic theory of gases relates observable properties of a gas to the motion of the molecules.

[2]

.....

.....

.....

.....



4. A solid block of glass is covered with water. The diagram shows the path of a monochromatic light ray entering the water from the glass block.

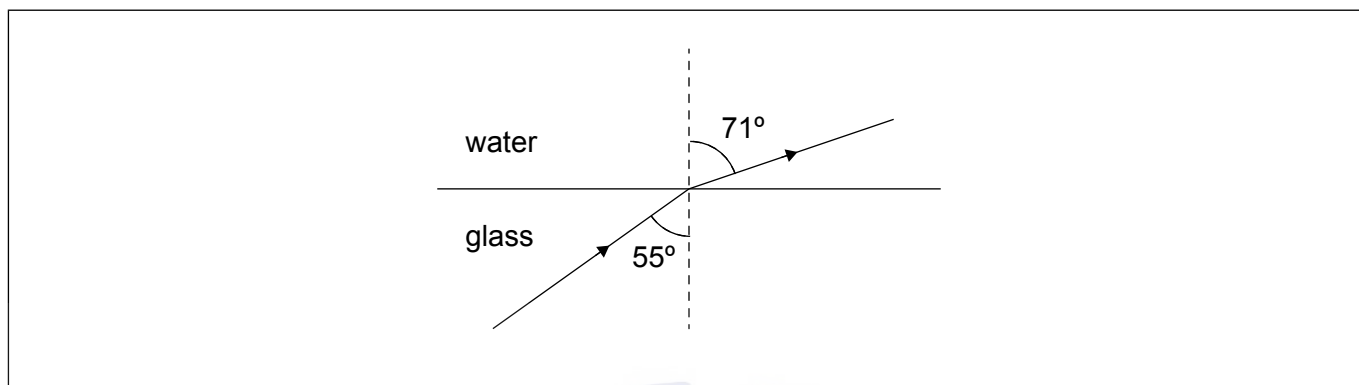

The speed of light in the glass is $2.0 \times 10^8 \text{ ms}^{-1}$.

- (a) Calculate the speed of light in the water. State the answer to an appropriate number of significant figures. [3]

.....

.....

.....

.....

.....

.....

- (b) Explain the change in the wavelength of the light at the glass–water boundary. [2]

.....

.....

.....

.....

(This question continues on the following page)



(Question 4 continued)

The light ray is partly reflected from the glass–water boundary.

- (c) Draw, on the diagram, the path of the reflected ray. [1]

The water is removed and replaced with air. The refractive index of air is 1.0. The direction of the incident light ray in the glass is unchanged.

- (d) Determine whether light emerges from the glass block into the air. [3]

.....

.....

.....

.....

.....

.....

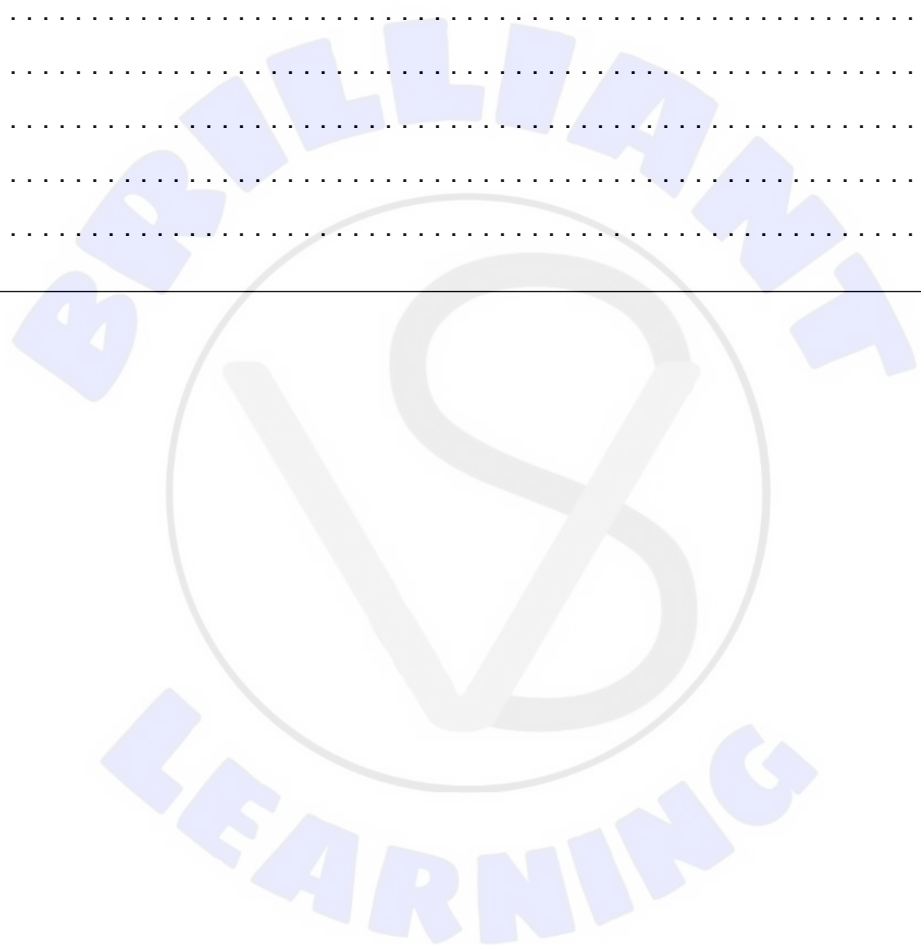

5. A $50.0\ \Omega$ resistor is connected to a cell of emf 3.00 V . The voltmeter and the ammeter in the circuit are ideal.

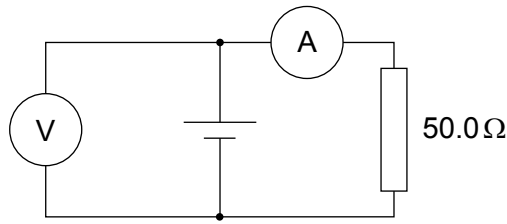

- (a) The current in the ammeter is 59.0 mA .

Calculate the internal resistance of the cell.

[2]

.....

.....

.....

.....

The circuit is changed by connecting another resistor R in parallel to the $50.0\ \Omega$ resistor.

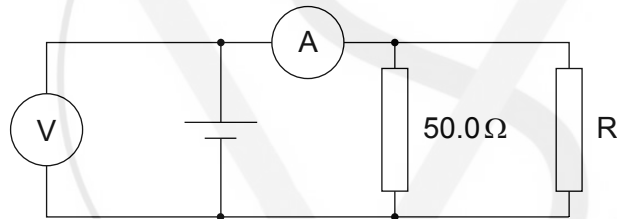

- (b) Explain the effect of this change on

(i) the reading of the ammeter.

[2]

.....

.....

.....

.....

(This question continues on the following page)



(Question 5 continued)

(ii) the reading of the voltmeter.

[2]

.....

.....

.....

.....

R is made of a resistive wire of uniform cross-sectional area $3.1 \times 10^{-8} \text{ m}^2$, resistivity $4.9 \times 10^{-7} \Omega \text{ m}$ and length L . The resistance of R is given by the equation

$$R = kL$$

where k is a constant.

(c) Calculate k . State an appropriate unit for your answer.

[3]

.....

.....

.....

.....

.....

.....

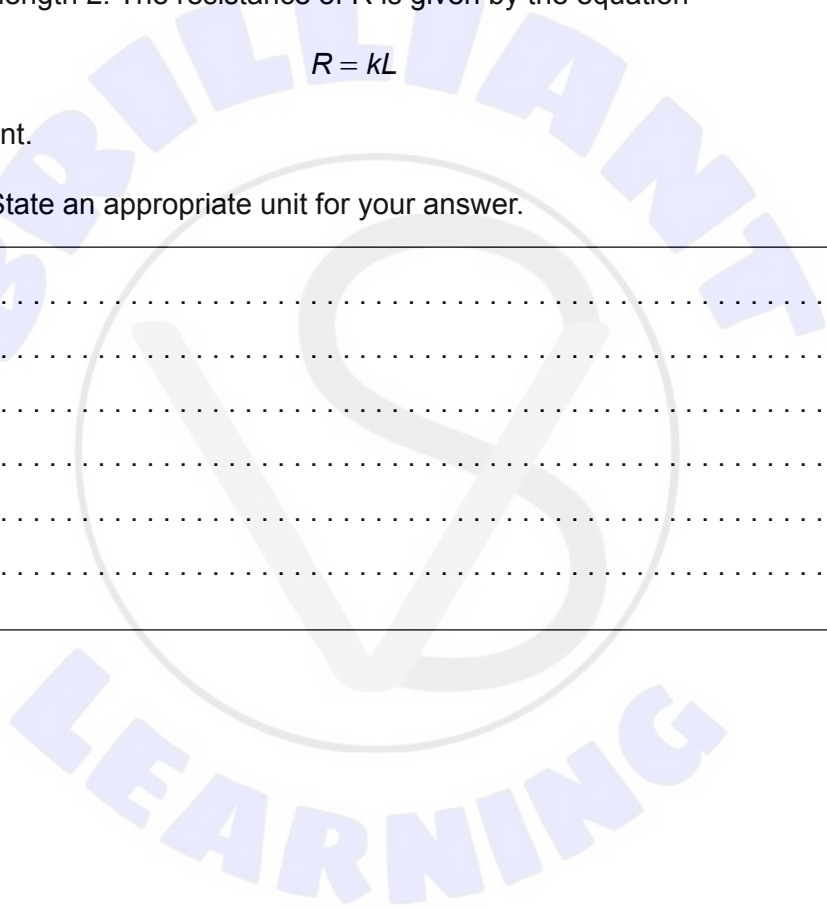

6. (a) State what is meant by the half-life of a radioactive nuclide. [1]

.....
.....
.....
.....

Tritium, ${}^3_1\text{H}$, is a radioactive isotope of hydrogen. The activity of a sample of tritium decreases to $\frac{A_0}{8}$ after a time of 37.0 years where A_0 is the initial activity.

(b) Calculate the half-life of tritium. [2]

.....
.....
.....
.....

Deuterium, ${}^2_1\text{H}$, and tritium undergo nuclear fusion according to:

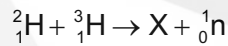

(c) Identify nuclide X. [1]

.....
.....
.....
.....

(This question continues on the following page)



(Question 6 continued)

The following data are given for binding energies per nucleon.

Nuclide	Binding energy per nucleon/MeV
${}^2_1\text{H}$	1.112
${}^3_1\text{H}$	2.827
X	7.074

(d) (i) Show that the energy released in this reaction is about 18 MeV. [2]

.....
.....
.....
.....

(ii) Outline why mass is not conserved in this reaction. [1]

.....
.....

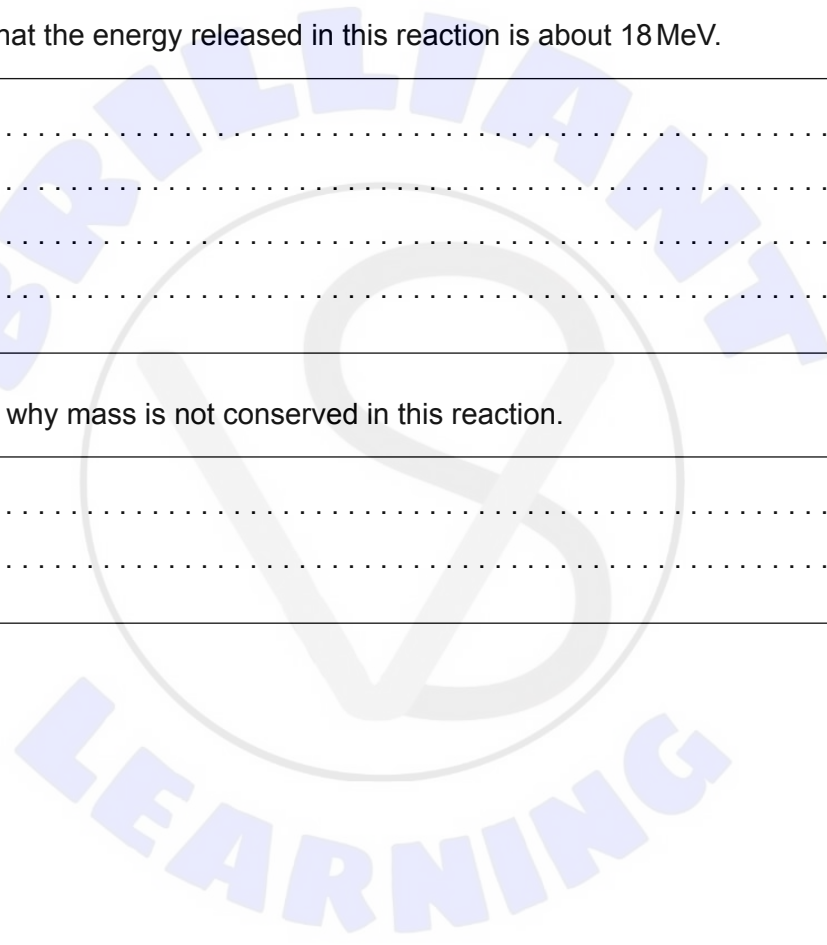

7. In a simplified model of energy balance of the Earth:

- the surface of the Earth absorbs incoming solar radiation of average global intensity I_0
- the surface emits thermal radiation of average intensity I_1
- some of the radiation emitted by the surface is absorbed by the atmosphere and re-emitted towards the surface. The average intensity of this radiation is I_2 .

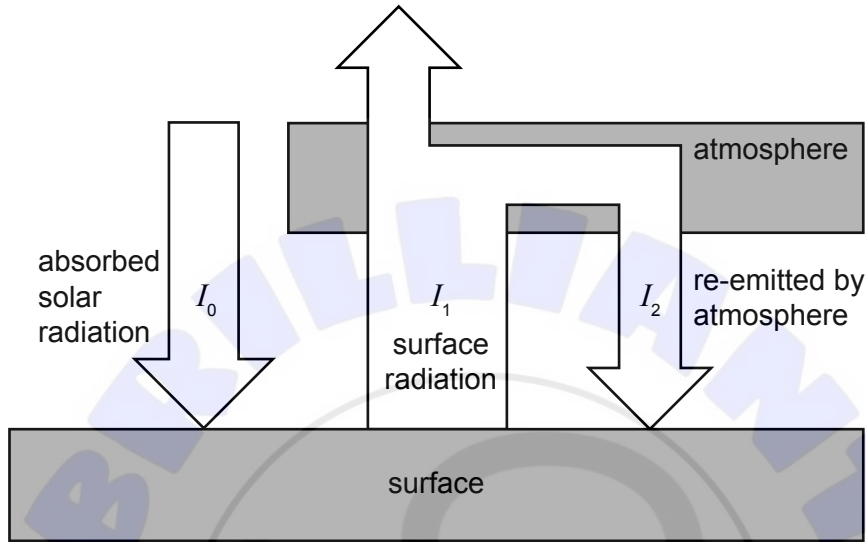

(a) Explain the effect of an increase in the concentration of greenhouse gases in the atmosphere on I_2 .

[2]

.....

.....

.....

.....

The following data are given.

$$I_0 = 240 \text{ W m}^{-2}$$
$$I_2 = 150 \text{ W m}^{-2}$$

(b) Determine the average temperature of the surface of the Earth according to this model.

[2]

.....

.....

.....

.....



8. A satellite orbits the Earth in a circular orbit of radius 1.0×10^7 m. At the orbital radius of the satellite, the gravitational field strength due to the Earth is 4.0 ms^{-2} .

(a) Show that the orbital speed of the satellite is about $6 \times 10^3 \text{ ms}^{-1}$. [2]

.....
.....
.....
.....

(b) Calculate the orbital period of the satellite. [2]

.....
.....
.....
.....

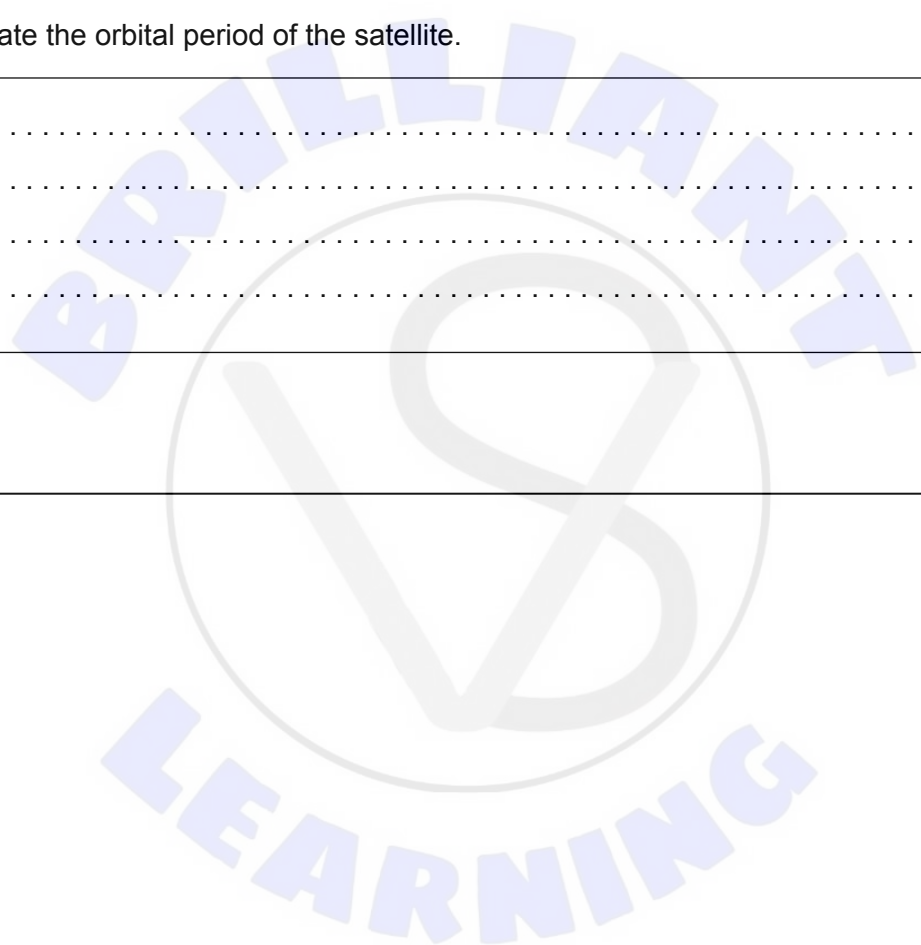

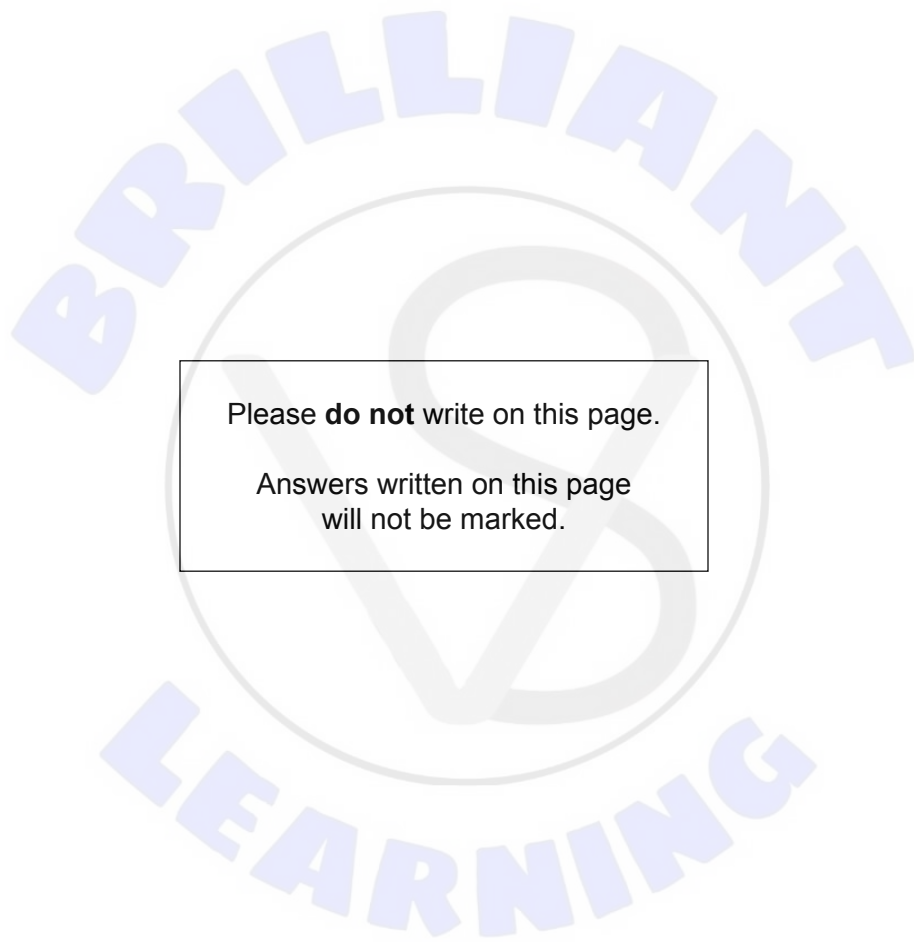

Please **do not** write on this page.

Answers written on this page
will not be marked.

