

2020 November Maths eAssessment



Question 1 (7 marks)



Below are seven puzzles, each with a missing section. From the draggable items, **select** the correct equivalent option to complete each puzzle.



Question 1a (1 mark)

Draggable:

6 : 4

24 : 36

1 : 3

16 : 24

The puzzle interface shows a red puzzle piece at the top with a notch containing the ratio $16 : 24$. Below it is a blue puzzle piece with a corresponding bump and a rectangular hole. To the left, three wooden draggable pieces are listed: $6 : 4$, $24 : 36$, and $1 : 3$. The interface also includes a mouse cursor icon, a trash can icon, and a refresh icon in the top right corner.



Question 1b (1 mark)

Draggable:

108×100

10.8×100

1080×100

1.08×10^4



Question 1c (1 mark)

Draggable:

$a^{\frac{14}{3}}$

a^6

a^{11}

$\frac{a^2 \times a^7}{a^3}$



Question 1d (1 mark)

Draggable:

0

$-b$

$3b$

$2a + b - 2(a - b)$



Question 1e (1 mark)

Draggable:

$\sqrt{24}$

$2a\sqrt{3}$

$2\sqrt{3}$

$a\sqrt{27} - a\sqrt{3}$



Question 1f (1 mark)

Draggable:

$4x - 3$

$4x + 1$

$4x - 1$

$4x^2 - 11x - 3$

$(x - 3)(\quad)$



Question 1g (1 mark)

Draggable:

$10x^2 + x - 2$

$10x^2 - x + 2$

$10x^2 - 9x - 2$

$(2x + 1)(5x - 2)$

Question 2 (8 marks)

Question 2a (3 marks)

The function $f(x) = -x(x - 5)$ is shown below.

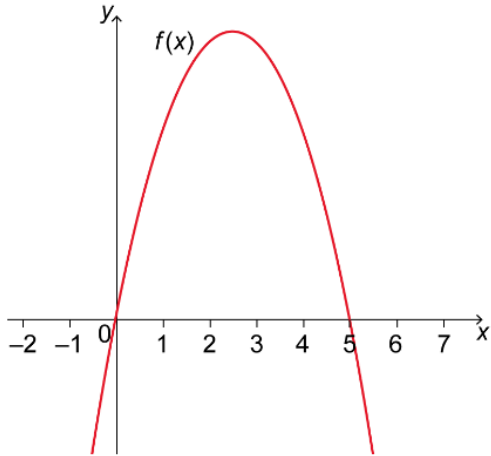

©

Calculate the maximum value of $f(x)$.

Rich text editor interface with a toolbar containing buttons for Bold (B), Italic (I), Undo, Redo, Underline (U), Subscript (x_2), Superscript (x^2), Bulleted List, Numbered List, Insert Link, and Insert Table. Below the toolbar is a text input area.



The function $f(x)$ is transformed to $g(x)$ by a translation of L units to the right. Press 'Next' to illustrate below.

This media is interactive

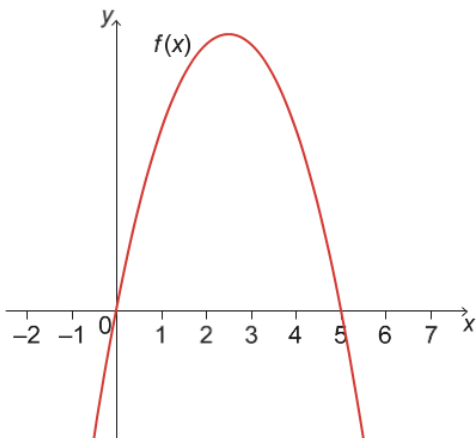

Next

©

Question 2b (1 mark)

Write down the value of L .

$L =$



Question 2c (2 marks)

Hence, determine the equation for $g(x)$.

Rich text editor interface with a toolbar containing buttons for Bold (B), Italic (I), Undo, Redo, Underline (U), Subscript (x_2), Superscript (x^2), Bulleted List, Numbered List, Insert Link, and Insert Table. Below the toolbar is a text input area.



Question 4 (12 marks)

An above-ground pool can be represented as a cylinder filled with water. If we look at the pool from above, we can see a circle.

This media is interactive

Diagram not to scale

Cylindrical pool

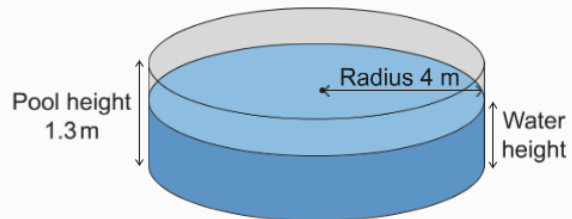
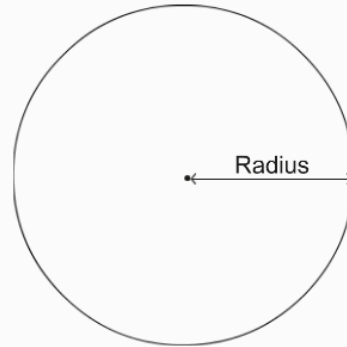
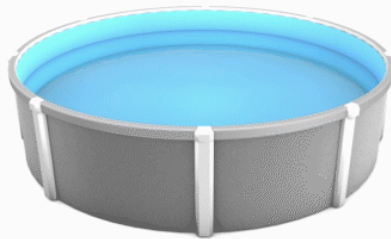

The pool height is 1.3 metres (m) and the radius of the pool is 4 m.

Question 4a (3 marks)

To avoid overflow, the pool is filled with water to 90 % capacity. **Show that** 90 % of the capacity is 58.8 m^3 , correct to three significant figures.



Question 5 (15 marks)

The following video explains the use of sleeves for paper cups.

Video

Script

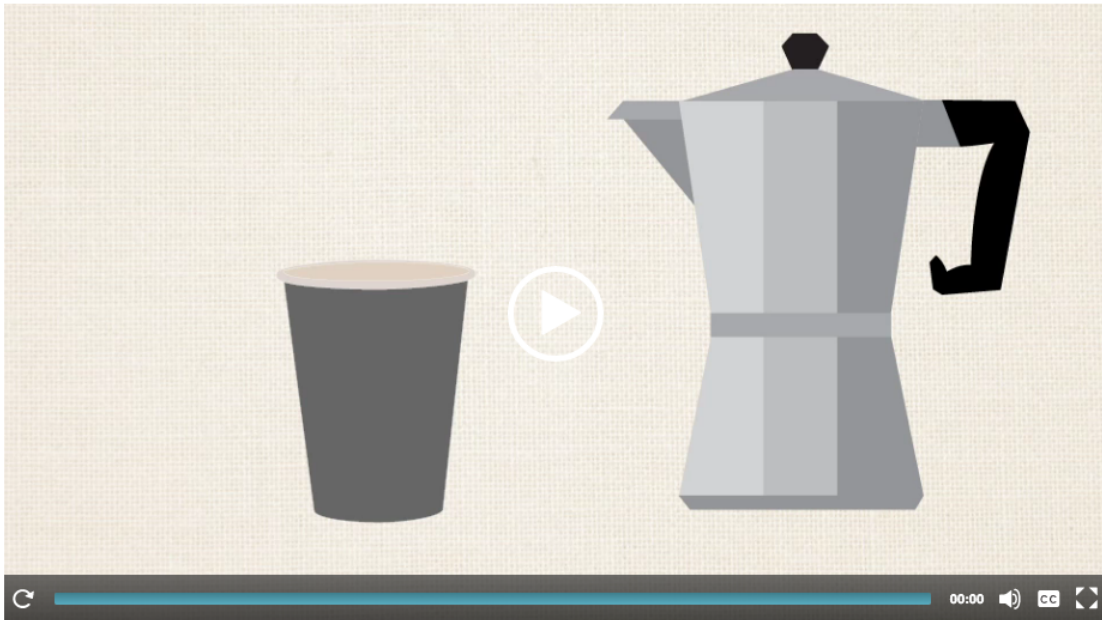

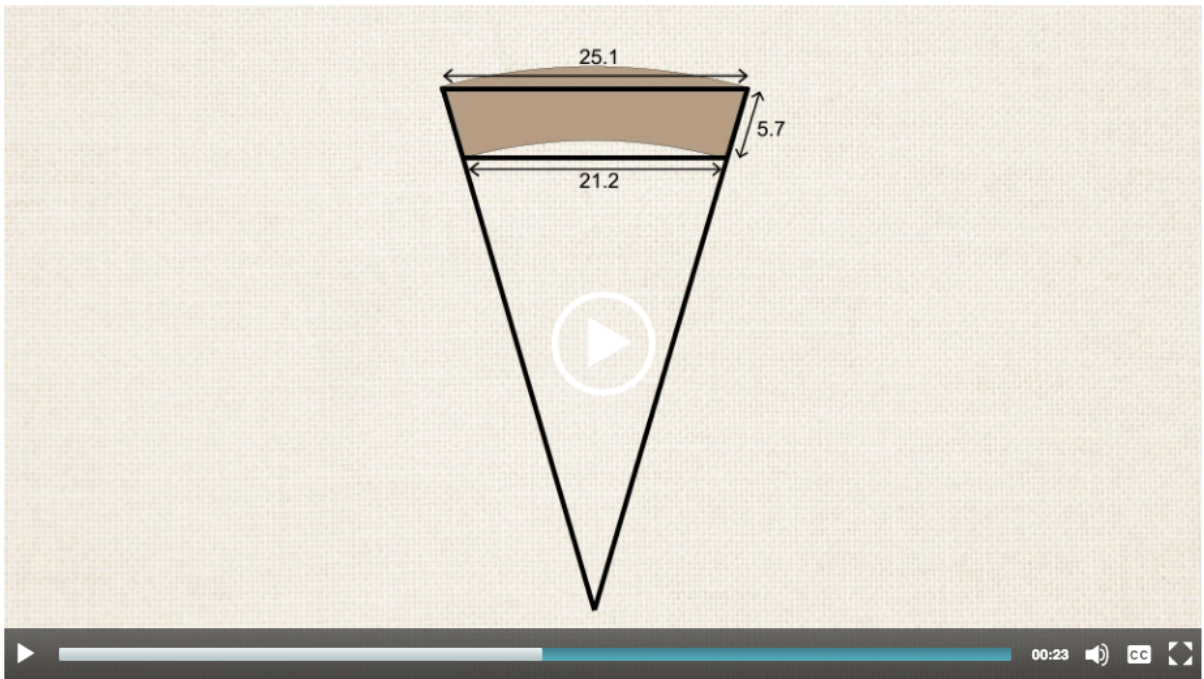
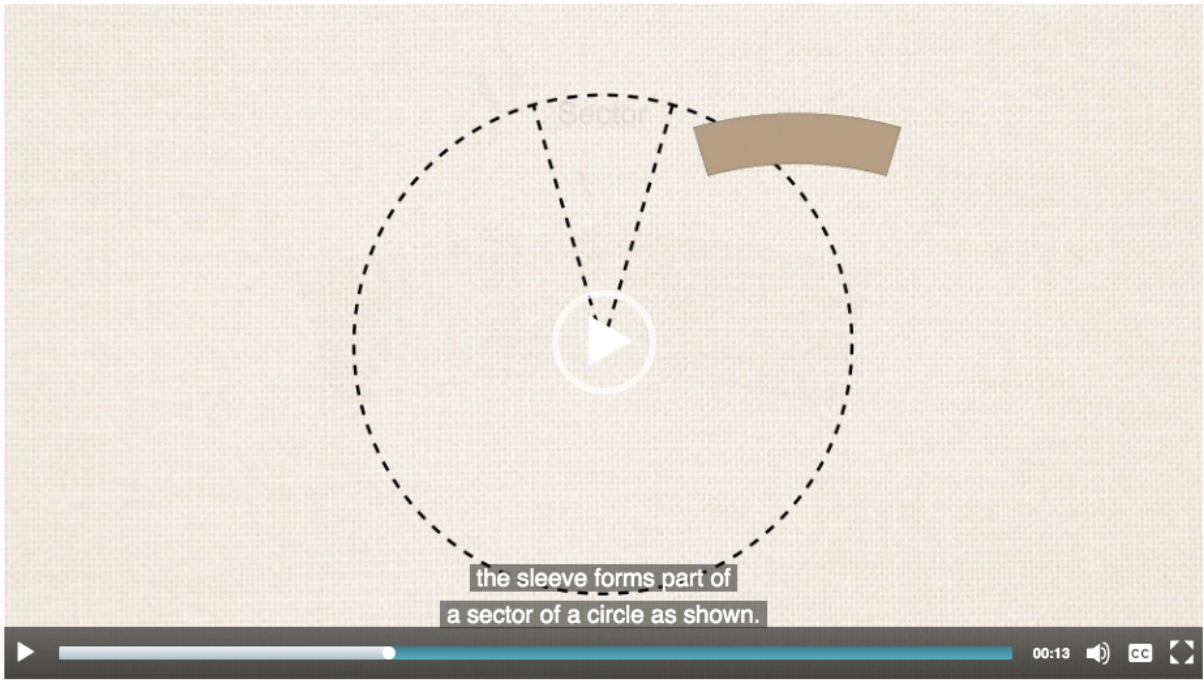



The dimensions of the sleeve are provided on the diagram, in centimetres (cm).

This media is interactive

Stage 2

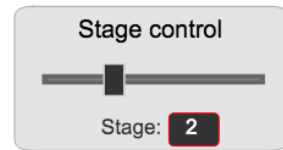
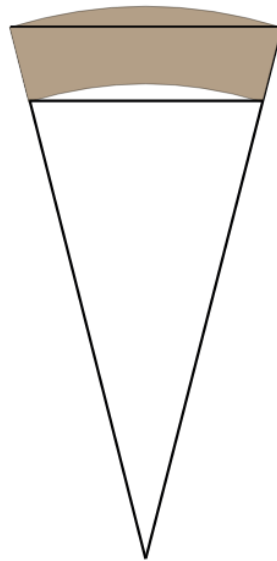

The dimensions of the sleeve are provided on the diagram, in centimetres (cm).

This media is interactive

Stage 3

Stage control

Stage: 3

©

The dimensions of the sleeve are provided on the diagram, in centimetres (cm).

This media is interactive

Stage 4

Stage control

Stage: 4

Question 5a (3 marks)

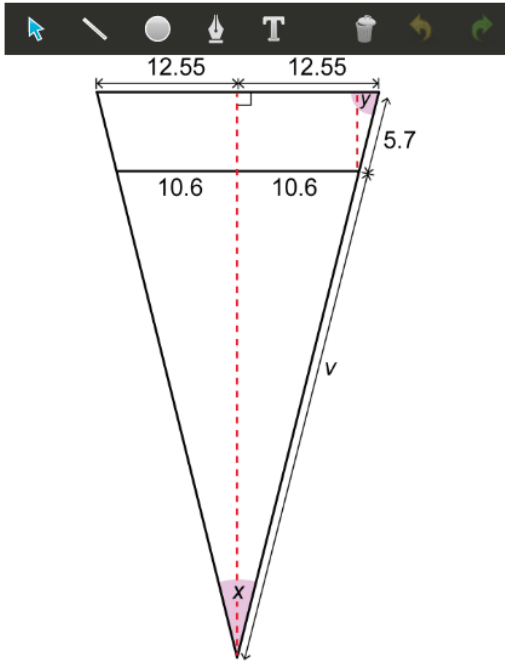

Show that the value of angle y is 70° , to the nearest degree.

Rich text editor toolbar with options: Bold (B), Italic (I), Undo, Redo, Underline (U), Text color (x), Background color (x²), Bulleted list, Numbered list, Link (Ω), and Unlink (Σ). Below the toolbar is a text input area.

Question 5b (2 marks)

Hence, determine the value of angle x , to the nearest degree.

Question 5c (3 marks)

Calculate the value of v .

Question 5d (4 marks)

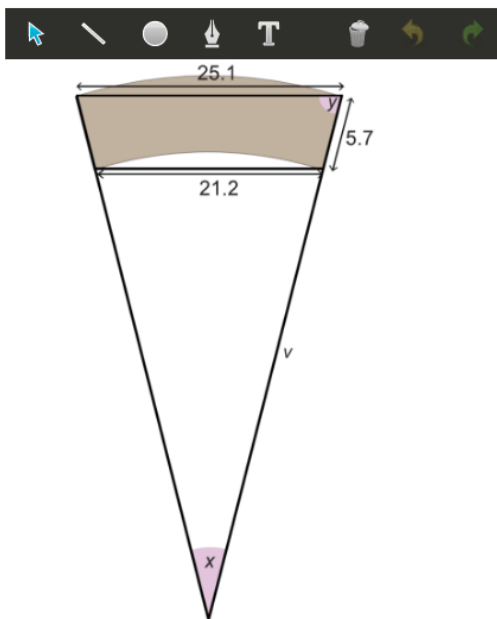

Find the area of the sleeve.

Rich text editor toolbar with options: Bold (B), Italic (I), Undo, Redo, Underline (U), Text color (x), Background color (x²), Bulleted list, Numbered list, Link (Ω), and Unlink (Σ). Below the toolbar is a text input area.



Question 5e (3 marks)

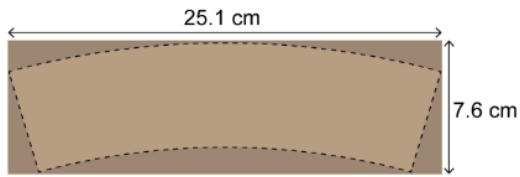

The sleeve is cut out from a 25.1 cm by 7.6 cm rectangle. Calculate the percentage of material wasted.

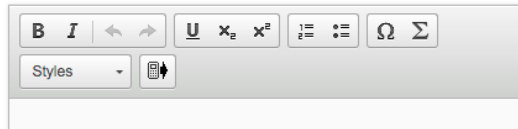

Question 6 (19 marks)



Many efforts have been made through the years to put into action solutions to resolve the problem of exposure to particulate matter in order to reach a globally agreed goal. In this question, you will make calculations and analyse exposure to particulate matter over a period of time.

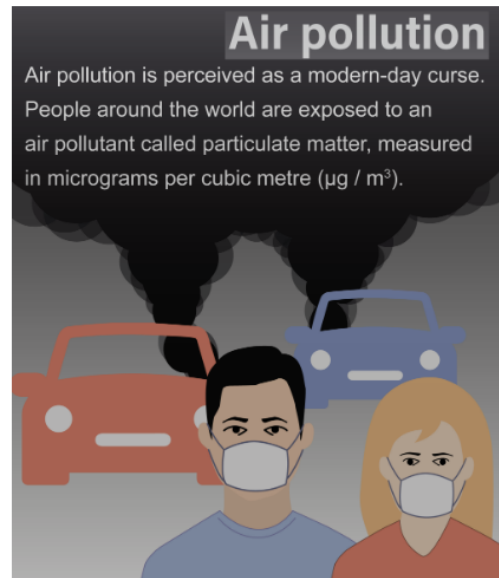

Question 6a (2 marks)

Annual exposure to particulate matter across Europe in 1990.

Annual exposure (E) to particulate matter in $\mu\text{g} / \text{m}^3$	$0 \leq E < 10$	$10 \leq E < 20$	$20 \leq E < 30$	$30 \leq E < 40$	$40 \leq E < 50$	$50 \leq E < 60$
Number of European countries	3	17	6	9	3	1

To visualize the level of exposure across Europe in 1990, use the table to **construct** a histogram.

Particulate matter for 1990

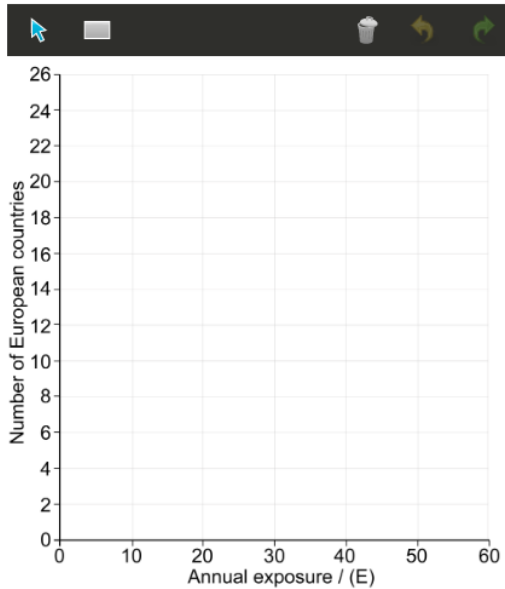

Below is the histogram for the annual exposure to particulate matter across Europe in 2016.

Particulate matter for 2016

This media is interactive

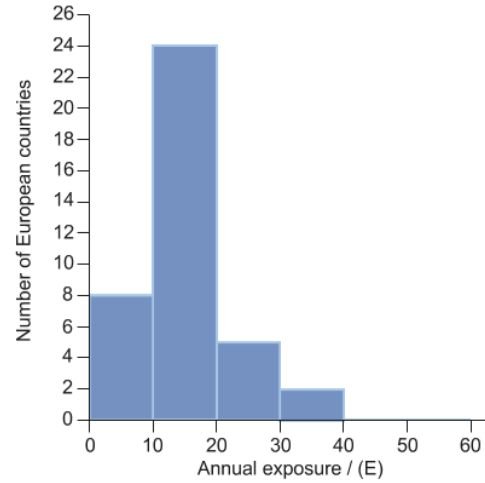

Question 6b (1 mark)

In comparison with your histogram in part (a), **state** one difference between annual exposure to particulate matter in 1990 and 2016.



Question 6c (4 marks)

Using the histogram for 2016, **show that** an estimate for the mean of E in 2016 is $15.3 \mu\text{g} / \text{m}^3$ to the nearest one decimal place.



Question 6d (2 marks)

The data from 1990 to 2016 can be modelled by a line of best fit as shown in Graph 1.

Graph 1

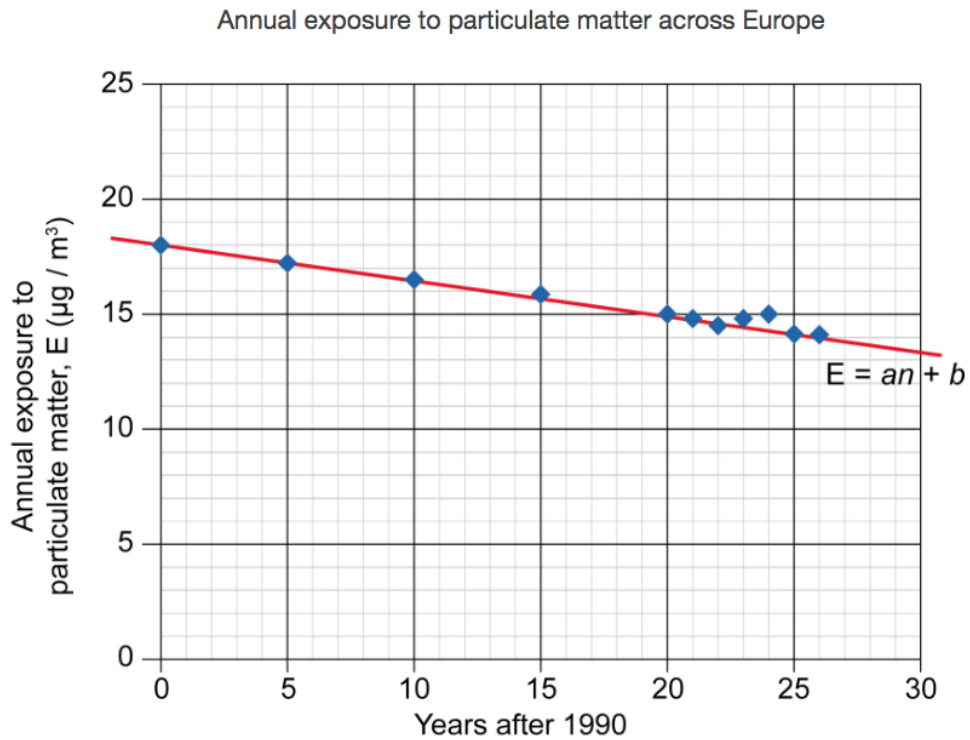

The equation of the line of best fit can be written as $E = an + b$, where E is the annual exposure to particulate matter and n is the number of years after 1990.

Determine the values of a and b .



Question 6e (10 marks)

The data from 1990 to 2016 can also be modelled by $E = 6(0.91)^n + 13.8$ as shown in Graph 2.

Graph 2

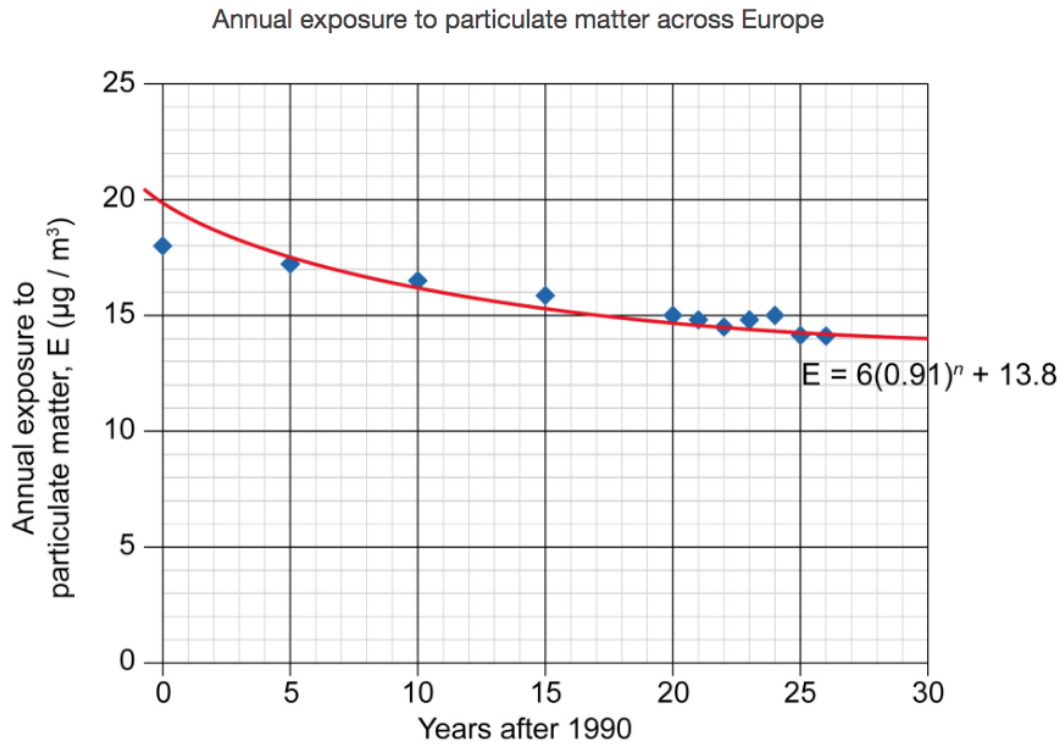

You are a statistical adviser on a government panel that wants to reduce annual exposure to particulate matter in Europe to a level below $13 \mu\text{g} / \text{m}^3$ by 2030. **Analyse** the two models to make a prediction of annual exposure to particulate matter in 2030. In your answer, you should:

- identify a factor from the data to be considered when making your prediction
- predict the level of annual exposure to particulate matter in 2030 using models from both graphs
- comment on the accuracy of your predictions
- advise the government which is a better model to make predictions and justify your answer.

Question 7 (30 marks)

In this task you will investigate perimeter and area of squares.

Question 7a (1 mark)

The square below has a side length of 3 units.



Show that the perimeter of the square is 12 units.

Rich text editor toolbar with buttons for Bold (B), Italic (I), Undo, Redo, Underline (U), Subscript (x₂), Superscript (x²), Bulleted list, Numbered list, Link, and Unlink. Below the toolbar is a text input area.

Drag the slider to see how the square is enlarged in different stages.

This media is interactive

Stage 4

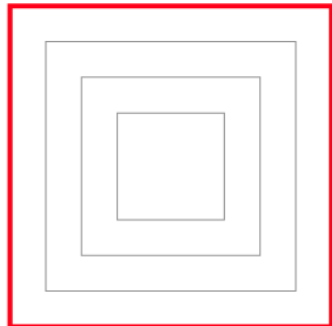

9

Stage control

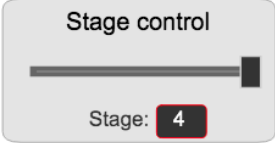

Stage: 4

Question 7b (2 marks)

Write down the missing values in the table up to row 6.

Stage number (n)	Perimeter of square (P)
1	12
2	20
3	28
4	36
5	
6	

Question 7c (2 marks)

Describe in words two patterns in the table for the perimeter of square (P).

Rich text editor toolbar with buttons for Bold (B), Italic (I), Undo, Redo, Underline (U), Subscript (x₂), Superscript (x²), Bulleted list, Numbered list, Link, and Unlink. Below the toolbar is a text input area.



Question 7d (2 marks)

Write down a general rule for P in terms of n .



Question 7e (3 marks)

Verify your general rule for P .



Question 7f (20 marks)

This media is interactive

Stage 4

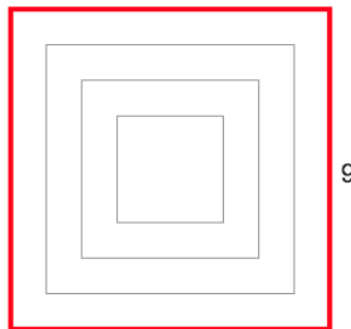

Stage control



Stage: 4

Stage number (n)	Area of square (A)	
1	9	
2	25	
3	49	
4	81	
5		
6		

Reset

Investigate the values in the table to find a relationship for the area of each square (A) in terms of n . In your answer, you should:

- predict more values and record these in the table
- describe in words a pattern in the table for area of square (A)
- write down a general rule for A in terms of n
- test your general rule for A
- verify and justify your general rule for A in relation to the squares
- ensure that you communicate all your working appropriately.