

mathmeoeengt0xxm



Markscheme

November 2024

Extended Mathematics

On-screen examination

32 pages



This markscheme is **confidential** and for the exclusive use of examiners in this examination session.

It is the property of the International Baccalaureate and must **not** be reproduced or distributed to any other person without the authorization of the IB Global Centre, Cardiff.

The markscheme abbreviations:

The markscheme may make use of the following abbreviation: **OE** – ‘or equivalent’

- Bullet notation means award 1 mark – see example below

Example 1
.1 mark awarded and corresponding notes are aligned

b	.1 Show clear line of reasoning in the method	.1 45 and 49 seen OE	2
	.2 4	<i>Ex:</i> $49 = 45 + x$.2	

Error Carried Forward (ECF) marks

Errors made at any step of a solution affect all working that follows. In general, **Error Carried Forward (ECF)** marks are awarded after an error.

- ECF** applies from one part of a question to a subsequent part of the question and also applies within the same part.
- If an answer resulting from **ECF** is inappropriate (eg, negative distances or $\sin x > 1$) then subsequent marks should not be awarded.
- If a question is transformed by an error into a **simpler question** then **ECF** may not be fully awarded.
- To award **ECF** marks for a question part, **there must be working present for that part**.
- ECF** is only applied to working which is correct. This means that all working subsequent to an error must be checked for accuracy.
- A misread (**MR**) is considered an error that allows ECF afterwards even if the rest of the question requires "the" result and not "their" result.

General notes

- As this is an international examination, accept all **alternative forms of notation**, for example 1,9 as 1.9 ; 1,000 or 1.000. However, **DO NOT ACCEPT** incorrect mathematical notation x^2 for x^2 unless noted otherwise in the MS.
- ACCEPT** notation errors in intermediate steps.
- Unless noted otherwise, ignore further working after a correct answer even if further working is incorrect.
- In the case when a correct result is obtained using incorrect seen method, do not award the mark for the result.
- Where candidates have written two solutions to a question, mark the first solution.
- In the markscheme, equivalent examples of **numerical** and **algebraic** forms or **simplified** answers will generally be written in the notes preceded by **OE** (Or Equivalent) e.g. $\frac{1}{2}$ or $1/2$ or 0.5 or $2 \div 4$; $\frac{x}{2}$ or $x/2$ or $x \div 2$; 0.23 or 23%
- In the markscheme, information provided in brackets indicate detail that may be seen in a candidate response but is not necessary to award the marks. However, it indicates what the candidate's result represents. Ex: if last mark is for the result: $(AB)=5$; this means we award the mark for seeing 5 as the result of calculating AB without necessarily seeing $AB=5$, but it does not mean we award the mark for seeing 5 representing another length.
- Special case marks **SC** can be allocated instead of but not in addition to the marks prescribed in the markscheme.
- ACCEPT** seeing equation not in-line or the fraction line missing.
- Calculator screenshots are accepted as working steps. And when a calculator screenshot is taken, accept not seeing the whole operation.
- In task 2 and 3 where the markscheme is set out in a table then, unless noted otherwise, awarding the highest mark in a category includes all the lower marks in that category. It is probably best to look for the top category mark answer and if you don't find it look at the next mark down.
- Unless noted otherwise, **ACCEPT** using the correct values or working regardless their previous result.
- Candidates will sometimes use methods other than those in the markscheme. Unless the question specifies a method, other correct methods should be marked in line with the markscheme. **If in doubt, contact your team leader for advice.**
- Unless noted otherwise, if a note in a part says to accept the answer without working for 1 mark less than total marks, then seeing the correct answer with any acceptable working step, award full marks. Example: If the note in a part worth 3 marks says "4.3(3...) without working award 2 marks", then seeing any acceptable working step and seeing 4.3(3...) as the answer award the 3 marks.
- For "**show that**" questions, unless otherwise noted, every bullet point has to be seen in order to be awarded.
- When a result is written as "their5.7(37...)" it means accept their result if its minimum accuracy is 1 dp. Providing higher accuracy is of course accepted but not required. Rounding their result incorrectly to nearest 1 dp is not accepted.
- When there are multiple alternative methods (multiple AM), mark the response using one specific AM. Do not add different marks from different AM.

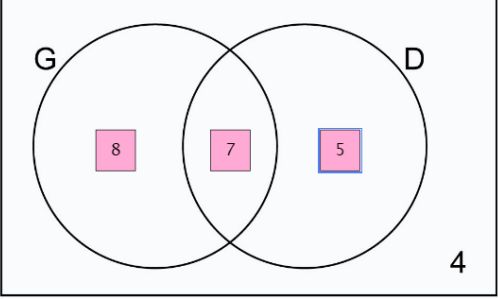
Q1	Answers	Notes	Total
a)	.1 Correctly write one value in the Venn diagram .2 Correctly write another two values in the Venn diagram		2
b)	Correctly write their probability from part a)	.1 their $\frac{15}{20}$ OE ACCEPT $\frac{their15}{20}$ provided probability < 1	1
d)	.1 Correct probability of first student from their part a) .2 Correctly write their three probabilities without replacement OR multiply their three probabilities with replacement .3 Correctly multiply their three probabilities without replacement	.1 their $\frac{20}{24}$ OE or 0.83(33...) ACCEPT 0.83 .1 ACCEPT $\frac{their20}{24}$ provided probability < 1 .2 their $\frac{20}{24}$, their $\frac{19}{23}$, their $\frac{18}{22}$ OR their $\frac{20}{24} \times \frac{20}{24} \times \frac{20}{24}$ OE .2 ACCEPT for bp2 only applying without replacement on only numerator or only denominator, <u>only if they multiply</u> their three probabilities Ex: their $\frac{20}{24} \times \frac{19}{24} \times \frac{18}{24}$.3 their $\frac{6840}{12144}$ or their $\frac{285}{506}$ or their 0.56(324...) OE	3

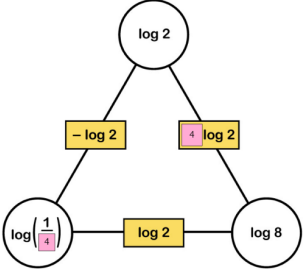
Q2	Answers	Notes	Total
a	.1 correctly place 4 .2 correctly place 4		2
b	.1 correctly apply power rule .2 correct value of A	.1 $(2\log 3 =) \log 9$ ACCEPT $\log 3^2$.2 $(A =) 45$ ACCEPT $\log 45$	2
c	.1 correctly apply difference of log .2 correct value of B	.1 $\log 180/9$ OR $\log 100/5$.1 ACCEPT $\log(9/180)$ OE only if they write $\log 9 - \log 180$.1 ACCEPT $\log(5/100)$ OE only if they write $\log 5 - \log 100$.2 $(B =) 20$ ACCEPT $\log 20$	2

Q3	Answers	Notes	Total
a	Correct equation	(T=)110n ACCEPT if equation not simplified Ex: 110+(n-1)110	1
b	.1 substitute correctly into the geometric sequence formula .2 correctly calculate the value for R after substitution	.1 256(0.5) ⁸⁻¹ OE ACCEPT dividing 256 by 2 at least 3 times .2 8	2
c	<p>AM1</p> <p>.1 correctly substitute into the geometric sequence formula.</p> <p>.2 correct algebraic step</p> <p>.3 correctly identify the value of n</p> <p>.4 correctly calculate their T (from their 3a) using their n in bp3</p> <p>AM2</p> <p>.1 correctly substitute a number for n and calculate R</p> <p>.2 correctly substitute 9 for n and equate to 1</p> <p>.3 correctly identify the value of n</p> <p>.4 correctly calculate their T (from their 3a) using their n in bp3</p>	<p>AM1</p> <p>.1 $256 \times \left(\frac{1}{2}\right)^{n-1} OE = 1$</p> <p>.2 $\frac{1}{256} = (0.5)^{n-1}$ or $256=(2)^{n-1}$ or $(2)^8=(2)^{n-1}$ OE or using logs Ex: $\log\left(\frac{1}{2}\right)^{n-1} = \log\frac{1}{256}$</p> <p>.3 (n=)9 ACCEPT 8=n-1 ACCEPT seeing n identified in next step</p> <p>.4 (their9×110=)their990 ACCEPT only of their n is a natural number (positive integer)</p> <p>AM2</p> <p>.1 $256 \times \left(\frac{1}{2}\right)^{11-1} OE = \frac{1}{4}$</p> <p>.2 $256 \times \left(\frac{1}{2}\right)^{9-1} OE = 1$</p> <p>.3 (n=)9 ACCEPT seeing n identified in next step</p> <p>.4 (their9×110=)their990 ACCEPT only of their n is a natural number (positive integer)</p>	4

c	<p>AM3</p> <p>.1 correctly continue the pattern for at least three terms</p> <p>.2 correctly continue the pattern until reaching 1</p> <p>.3 correctly identify the value of n</p> <p>.4 correctly calculate their T (from their 3a) using their n in bp3</p>	<p>AM3</p> <p>.1 $(512/2)=256, (256/2)=128, (128/2)=64$ OR $(256/2)=128, (128/2)=64, (64/2)=32$</p> <p>.2 $(512/2)=256, (256/2)=128, (128/2)=64, (64/2)=32, (32/2)=16, (16/2)=8, (8/2)=4, (4/2)=2, (2/2)=1$ OR $(256/2)=128, (128/2)=64, (64/2)=32, (32/2)=16, (16/2)=8, (8/2)=4, (4/2)=2, (2/2)=1$</p> <p>.3 $(n=)9$ ACCEPT seeing n identified in next step</p> <p>.4 $(\text{their}9 \times 110 =) \text{their}990$ ACCEPT only of their n is a natural number (positive integer)</p> <p>For any AM Bp2 implies bp1</p>	<p>4</p>
---	---	---	-----------------

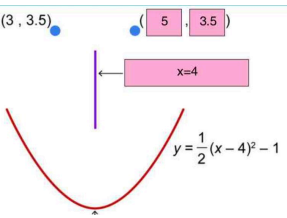
Q4	Answers	Notes	Total
a	<p>From the 3 elements (5, 3.5, x=4)</p> <p>.1 Any two correct .2 third correct</p>	 <p>For x=4, DO NOT ACCEPT if not equation</p>	2
b	Correct value for a	2	1
c	<p>AM1</p> <p>.1 Correctly expand $(x - 4)^2$.2 Correctly multiply the three terms by half AG $(y =) \frac{1}{2}x^2 - 4x + 7$</p> <p>AM2</p> <p>.1 Correctly take $\frac{1}{2}$ as common factor .2 Correctly completing the square AG $(y =) \frac{1}{2}(x - 4)^2 - 1$</p>	<p>AM1</p> <p>.1 $(y =)x^2 - 8x + 16$ ACCEPT $x^2 - 4x - 4x + 16$.2 $(y =) \frac{1}{2}x^2 - 4x + 8$</p> <p>AM2</p> <p>.1 $(y =) \frac{1}{2}(x^2 - 8x + 14)$.2 $(y =) \frac{1}{2}((x - 4)^2 - 4^2 + 14))$</p> <p>For both AM This is a show that question so each bp must be seen to award the mark Ex: seeing only $(y =)x^2 - 8x + 16$ is only bp1 Ex: seeing only $(y =) \frac{1}{2}x^2 - 4x + 8$ is only bp2</p>	2

<p>d</p>	<p>AM1 using the form $\frac{1}{2}(x - 4)^2 - 1$.1 Correctly substitute 0 into the equation .2 Correct rearrangement for the $(x - 4)^2$ on one side .3 Correctly solve the quadratic .4 The correct x-intercepts to nearest one decimal place (as coordinates) AM2 using the form $\frac{1}{2}x^2 - 4x + 7$.1 Correctly substitute 0 into the equation .2 Correctly substitute the coefficients into quadratic formula .3 Correctly solve the quadratic .4 The correct x-intercepts to nearest one decimal place (as coordinates)</p>	<p>AM1 .1 $\frac{1}{2}(x - 4)^2 - 1 = 0$ OE .2 $(x - 4)^2 = 2$.3 $(x =)4 - \sqrt{2}$ or 2.585(786...) AND $(x =)4 + \sqrt{2}$ or 5.414(21...) .3 ACCEPT 4-1.41 or and 4+1.41 .4 (2.6, 0) AND (5.4, 0) ACCEPT 2.6 and 5.4 AM2 .1 $\frac{1}{2}x^2 - 4x + 7 = 0$ OE .2 $(x =) \frac{4 \pm \sqrt{(-4)^2 - 4(0.5)(7)}}{2(0.5)}$ OE ACCEPT if only one mistake in a sign or in substituting a coefficient Ex: $(x =) \frac{4 \pm \sqrt{(-4)^2 - 4(0.5)(7)}}{2(0.5)}$ or $\frac{4 + \sqrt{(4)^2 - 4(0.5)(7)}}{2(0.5)}$ or $\frac{4 - \sqrt{(-4)^2 - 4(0.5)(7)}}{2(0.5)}$ or $\frac{4 \pm \sqrt{-16 - 4(0.5)(7)}}{2(0.5)}$ or $\frac{-(-4) \pm \sqrt{(4)^2 - 4(0.5)(7)}}{2}$ or $\frac{4 \pm \sqrt{(4)^2 - 4(7)}}{2(0.5)}$ or $\frac{4 \pm \sqrt{(-4) - 4(0.5)(7)}}{2(0.5)}$ or $\frac{4 \pm \sqrt{(-4)^2 - 4(0.5)}}{2(0.5)}$.3 $(x =)4 - \sqrt{2}$ or 2.585(786...) AND $(x =)4 + \sqrt{2}$ or 5.414(21...) ACCEPT 4-1.41 or and 4+1.41 .4 (2.6, 0) AND (5.4, 0) ACCEPT 2.6 and 5.4</p>	<p>4</p>
-----------------	--	--	-----------------

<p>c</p>	<p>AM1 using the form $\frac{1}{2}(x - 4)^2 - 1$.1 Correctly substitute 0 into the equation .2 Correct rearrangement for the $(x - 4)^2$ on one side .3 Correctly solve the quadratic .4 Correctly write both of the x-intercepts to nearest one decimal place as coordinates</p> <p>AM2 using the form $\frac{1}{2}x^2 - 4x + 7$.1 Correctly substitute 0 into the equation .2 Correctly substitute the coefficients into quadratic formula .3 Correctly solve the quadratic .4 Correctly write both of the x-intercepts to nearest one decimal place as coordinates</p>	<p>AM1 .1 $\frac{1}{2}(x - 4)^2 - 1 = 0$.2 $(x - 4)^2 = 2$.3 $(x =) 4 - \sqrt{2}$ or 2.585(786...) AND $(x =) 4 + \sqrt{2}$ or 5.414(21...) .3 ACCEPT 4-1.41 or and 4+1.41 .4 (2.6, 0) AND (5.4, 0)</p> <p>AM2 .1 $\frac{1}{2}x^2 - 4x + 7 = 0$.2 $(x =) \frac{4 \pm \sqrt{(-4)^2 - 4(0.5)(7)}}{2(0.5)}$ OE ACCEPT if only one mistake in a sign or in substituting a coefficient Ex: $(x =) \frac{-4 \pm \sqrt{(-4)^2 - 4(0.5)(7)}}{2(0.5)}$ or $\frac{4 \pm \sqrt{(-4)^2 - 4(0.5)(7)}}{2(0.5)}$ or $\frac{4 - \sqrt{(-4)^2 - 4(0.5)(7)}}{2(0.5)}$ or $\frac{4 \pm \sqrt{-16 - 4(0.5)(7)}}{2(0.5)}$ or $\frac{4 \pm \sqrt{(-4)^2 - 4(0.5)(7)}}{2}$ or $\frac{4 \pm \sqrt{(-4)^2 - 4(7)}}{2(0.5)}$ or $\frac{4 \pm \sqrt{(-4) - 4(0.5)(7)}}{2(0.5)}$ or $\frac{4 \pm \sqrt{(-4)^2 - 4(0.5)}}{2(0.5)}$.3 $(x =) 4 - \sqrt{2}$ or 2.585(786...) AND $(x =) 4 + \sqrt{2}$ or 5.414(21...) ACCEPT 4-1.41 or and 4+1.41 .4 (2.6, 0) AND (5.4, 0)</p> <p>For AM1 or AM2: solving the quadratic correctly for only one value and writing this value correctly to nearest one decimal place as coordinates award bp3</p> <p>For any AM: bp2 implies bp1</p>	<p>4</p>
-----------------	--	---	-----------------

Q5 EXT	Answers	Notes	Total
a	.1 Correctly substitute 28, 20 and 12 into cosine rule. .2 Correct value of cosABC .3 Correct value for their angle ABC after applying cosine rule	.1 $28^2 = 20^2 + 12^2 - 2(20)(12)\cos ABC$ OE or $(\cos ABC =) \frac{(20^2 + 12^2 - 28^2)}{2(20)(12)}$ OE .1 ACCEPT one mistake in a number or a sign .2 $(\cos ABC =) -\frac{1}{2}$ OE .3 (angleABC=) their 120 (degrees) or $\frac{2}{3}\pi$ or 2.09(...)rad .3 ACCEPT only if obtuse angle .3 DO NOT ACCEPT if their substitution includes more than one mistake	3
b	AM1 .1 Correct length ratio .2 the correct value of EC AM2 .1 Correctly calculate angle D .2 the correct value of EC	AM1 .1 15/20 OE or 20/15 OE .2 $(15/20 * 12) = 9$ AM2 .1 (D=)21.768... ACCEPT 21.8 or 22 .2 (EC=)9(...)	2

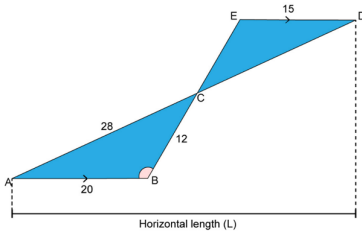
<p>c</p>	<p>AM1 Using triangle MBC</p> <ol style="list-style-type: none"> .1 Correctly calculate their angle MBC .2 Correctly substitute their MBC and 12 into trig ratio .3 Correct value for their BM .4 Correct value for their NE after applying their ratio from part b .5 The correct L after adding all horizontal values <p>AM2 Using triangle MAC</p> <ol style="list-style-type: none"> .1 Correctly calculate their angle BAC (using sine or cosine rules) .2 Correctly substitute their MAC and 28 into trig ratio .3 Correct value for their AM .4 Correct ND after correctly applying their ratio from part b .5 The correct L after adding all horizontal values <p>AM3 Using triangle PAD</p> <ol style="list-style-type: none"> .1 Correctly calculate their angle BAC (using sine or cosine rules) .2 Correctly substitute their EDC(=BAC) and 15 into trig ratio .3 Correct value for their CD .4 Correctly substitute AC+CD and angle BAC into trig ratio .5 The correct L after adding all horizontal values 	 <p>AM1 Using triangle MBC</p> <ol style="list-style-type: none"> 1. 180 – their120 or their60 .2 $\cos \text{their}60 = \frac{BM}{OE}$.3 $(12 \cdot \cos(\text{their}60)) = \text{their}6$.4 $((3/4) \cdot \text{their}6 =)\text{their} 4.5$ ACCEPT seeing directly $(4.5+6=)10.5$.5 $(20+6+4.5+15 =) 45.5$ ACCEPT 46 <p>AM2 Using big triangle MAC</p> <ol style="list-style-type: none"> .1 $(\sin^{-1}(12 \cdot \sin \text{their}120 / 28) =) \text{their} 21.786789$ ACCEPT 22 .2 $\cos \text{their}22 = \frac{AM}{OE}$.3 $(28 \cdot \cos(\text{their}22) =)\text{their} 25.96(11579\dots)$.4 $(\frac{3}{4} \cdot \text{their}26 =)\text{their} 19.5$.5 $(26+19.5=)45.5$ ACCEPT 46 <p>AM3 Using triangle PAD</p> <ol style="list-style-type: none"> .1 $(\sin^{-1}(12 \cdot \sin \text{their}120 / 28) =) \text{their} 21.786789$ ACCEPT 22 .2 $\frac{\sin(\text{their}60 - \text{their}22)}{15} = \frac{\sin(\text{their}120)}{CD}$.3 their 21.1 .4 $\cos \text{their}22 = \frac{L}{\text{their}21+28}$.5 45.5 ACCEPT 46 	<p>5</p>
-----------------	---	---	----------

	<p>AM4</p> <p>.1 Correctly calculate CD .2 Correct AD .3 Correctly calculate their angle BAC (using sine or cosine rules) .4 Correctly substitute AC+CD and angle BAC into trig ratio .5 The correct L after adding all horizontal values</p>	<p>AM4</p> <p>.1 $(15 \times 28 / 20 = 21)$.2 $(21 + 28 =) 49$.3 $(\sin^{-1}(12 \times \sin \theta / 28) =) \theta = 21.786789$ ACCEPT 22 .4 $\cos \theta = \frac{L}{\sin \theta (21 + 28)}$.5 45.5 ACCEPT 46</p>	
--	---	---	--

Q6	Answers	Notes	Total								
a	From the 8 things: 3 inequalities 3 constraints matching their inequalities .1 two correct .2 third correct .3 fourth correct .4 fifth and sixth correct	<table border="1" data-bbox="815 808 1385 992"> <thead> <tr> <th data-bbox="815 808 927 853">Inequalities</th> <th data-bbox="927 808 1385 853">Constraints</th> </tr> </thead> <tbody> <tr> <td data-bbox="815 853 927 898">$x \geq 2.3$</td> <td data-bbox="927 853 1385 898">(The width of one cycle path is) at least 2.3 m WTTE</td> </tr> <tr> <td data-bbox="815 898 927 943">$y \geq 2.5$</td> <td data-bbox="927 898 1385 943">(The width of one car lane is) at least 2.5 m WTTE</td> </tr> <tr> <td data-bbox="815 943 927 992">$y \geq x$</td> <td data-bbox="927 943 1385 992">(The width of one car lane is) greater than or equal to width of one cycle path WTTE</td> </tr> </tbody> </table> <p data-bbox="815 1014 1385 1055">For incorrect strictness of inequalities deduct only one mark For their constraint with incorrect strictness deduct only one mark</p>	Inequalities	Constraints	$x \geq 2.3$	(The width of one cycle path is) at least 2.3 m WTTE	$y \geq 2.5$	(The width of one car lane is) at least 2.5 m WTTE	$y \geq x$	(The width of one car lane is) greater than or equal to width of one cycle path WTTE	4
Inequalities	Constraints										
$x \geq 2.3$	(The width of one cycle path is) at least 2.3 m WTTE										
$y \geq 2.5$	(The width of one car lane is) at least 2.5 m WTTE										
$y \geq x$	(The width of one car lane is) greater than or equal to width of one cycle path WTTE										
b	.1 Correct vertex .2 Correct vertex	.1 (Vertex) A or (2.3, 3.7) .2 (Vertex) D or (3, 3)	2								
c	.1 Correctly write upper bound of a cost .2 Correctly multiply their two costs by 5 OR correctly add their upper bound costs .3 Correct answer	.1 1.25 or 3.15 ACCEPT correctly writing upper bound for their total cost Ex: 4.35 for 4.3 or 21.55 for 21.5 .2 (5xtheir1.25=)their6.25 and (5xtheir3.15=)their15.75) OE OR their1.25+their3.15=their4.4 .2 ACCEPT (5x1.2=)6 and 15.5 .2 DO NOT ACCEPT only adding 1.2+3.1=4.3 .3 22 (million) .3 DO NOT ACCEPT 22 as upper bound for 21.5	3								

Q7	Answers	Notes	Total
a	.1 Substitute 15 and 240 into volume of cone formula .2 Correctly calculate their volume .3 Correctly calculate their answer after subtracting 32720 from their bp2 .4 Correctly round to nearest 10 cm ³	.1 ($V =$) $15^2 \times \pi \times \frac{240}{3}$ ACCEPT using $\frac{22}{7}$ or 3.14 instead of π .2 ($V=$) their 56 548.66776 or 56 548.67 or 56 549 or 56520 using 3.14 or 56571.(4...) using $\frac{22}{7}$.2 ACCEPT [56 520, 56 572] .2 ACCEPT their calculated volume if only one of the following is incorrect, or missing, in their multiplication : 15, 240, 1/3, π .3 (their 56 548.66776 – 32 720 =) 23 828.6(6776) or 23829 ACCEPT [23800, 23852] .4 their 23 830 .4 ACCEPT correctly rounding their result in bp2 to nearest 10 cm ³ .4 DO NOT ACCEPT if their result does not need rounding	4
b	AM1 .1 Multiply their volume of pot by 0.9 .2 Correctly write their calculated result in litres. AM2 .1 Correctly write their 23830 in litres .2 Correctly multiply their volume by 0.9	AM1 .1 their 23830 x 0.9 OE or their 21 447 .2 (their 21 447 / 1000 =) their 21(.447) or 21.5 AM2 .1 their 23.8(3...) .2 (their 23.8(...)x0.9=) their 21(.447) or 21.5 ACCEPT seeing their 21447 written in letters in 7c	2
c	.1 Multiply their 7b by 0.4 .2 Correctly add the cost of their three components for one plant	.1 their 21 x 0.4 or their 8.4 .2 (their 8.4 + 6 + 1.5 =) their 15.9 .2 ACCEPT if their 8.4 is 0.4 or any other number	2
d	Correct value for L1	160	1

e	<p>AM1 .1 Correctly substitute 40 and 80 into Pythagoras OR correct substitution into trig ratio .2 The correct vertical distance between two centres .3 Correctly add 80 to their bp2</p> <p>AM2 .1 correctly calculate half distance between two centres .2 The correct vertical distance between two centres .3 Correctly add 80 to their bp2</p>	<p>AM1 .1 $x^2+40^2=80^2$ OE OR $\frac{40}{\tan 30}$ or $40 \times \tan 60$ or $80 \times \sin 60$ or $80 \times \cos 30$.2 69(.282...) ACCEPT 70 .3 (their69.28.. + 80 =) their149(.282...) ACCEPT 150 .3 ACCEPT even if none of bp1 or bp2 are awarded</p> <p>AM2 .1 34.64(...) .2 (2x34.64=) 69(.282...) ACCEPT 70 .3 (their69.28.. + 80 =) their149(.282...) ACCEPT 150 .3 ACCEPT even if none of bp1 or bp2 are awarded</p>	<p style="text-align: center;">3</p>
---	--	--	---

Q7f total 10 marks

Mark	1	2
Factors (F)	<p>Two from the factors below mentioned in the factors box WTTE</p> <ul style="list-style-type: none"> ⇒ Space for plant to grow ACCEPT distance between pots or distance between centres, circumference or area of the pot, the circle of the plant, space for people (to walk or to sit...), space unoccupied ⇒ Dimensions of garden ACCEPT the space available, area of the roof, the 290 and the 360, length and width of garden ⇒ The arrangement of pots ACCEPT The formation, the way we place the pots, the triangular, square, calling the triangular formation honeycomb <p>DO NOT ACCEPT number of plants able to fit DO NOT ACCEPT other irrelevant factors. Ex: enough sunlight, the budget or cost, number of pots in each row, covering shield for plants, aesthetically appealing</p>	<p>The three factors mentioned in the factors box WTTE</p>

Mark	1	2	3
			ACCEPT only if D2 is achieved
Calculate (C)	Correct calculation for their horizontal direction Ex: $360/80=4.5$ or their 4×80	Correct calculation for their horizontal direction Ex: $360/80=4.5$ or their 4×80 Ex for triangular: their $4 \times$ their $69+80=$ their 360 OE ACCEPT their $4 \times$ their $69+80 < 360$ OE	Correct calculation for the horizontal direction in the case of 15 or 16 pots Ex: $4 \times 70+80=360$ or $4 \times 69+80 < 360$
	OR Correct calculation for their vertical direction Ex: $290/80=3.6(25)$ or their 3×80	AND Correct calculation for their vertical direction Ex: $290/80=3.6(25)$ or their 3×80 Ex for triangular: their $3 \times$ their $70 + 80 =$ their 290 OE ACCEPT their $3 \times$ their $69 + 80 < 290$	AND Correct calculation for the horizontal direction in the case of 15 or 16 pots Ex: $3 \times 70 + 80 = 290$ or $3 \times 69+80 < 290$
	OR Their cost based on their design: Their number of pots \times their $7c$	OR Correct calculation for their cost based on their design regardless of rounding Their number of pots \times their $7c$	AND Correct calculation for their cost based on their design regardless of rounding Their number of pots \times their $7c$
	OR Correct calculation for area of one pot as 5026.5 and area roof as 104400 or Correct calculation of area between the circles for their arrangement whether square or triangle	AND Correct calculation of area between the circles for their arrangement whether square or triangle OR correct calculation for the maximum number of pots based on area: $\frac{290 \times 360}{\pi \times 40^2} = 20.7(69 \dots)$	

Mark	1	2
Design on canvas (D)	<p>Design includes 12 to 14 non-overlapping plants ACCEPT minor overlaps and use professional judgement</p> <p style="text-align: center;">OR</p> <p>Design includes 14 to 16 with only one clear overlap between plants</p> <p>See examples below</p>	<p>Design includes 15 or 16 non-overlapping plants ACCEPT minor overlaps and use professional judgement</p> <p>See examples below</p>

Mark	1
Accuracy (A)	<p>Correct sensible degree of accuracy for the calculation of the product of their 7c by their number of plants on canvas: (their 7c x their 16 =) their 257.6 or their 258 or their 260 ACCEPT if they correctly round up their 7c, DO NOT ACCEPT if they round down their 7c DO NOT ACCEPT if accurate to more than two decimal places (more than nearest cent)</p> <p>ACCEPT Correct sensible rounding in any calculation</p> <p>Examples: For area of one pot: 5030 For total area/area of pot: 20.7 so 20 plants For the number of plants: $360/80=4.5$ so 4 or one below and they use 4, or $290/80=3.6$ so 3 or one below and they use 3</p>

Mark	1	2
	ACCEPT only if D1 is achieved	ACCEPT only if D2 is achieved
Justify (J)	<p>Acceptable justification for their arrangement</p> <p>Examples:</p> <ul style="list-style-type: none"> - I respected all the requirements (and we see the canvas with requirements respected) - I provided good space for movement between plants - Not very accurate as I rounded values - My calculations are approximations 	<p>Acceptable justification for the arrangement of 15 or 16 pots</p> <p>Examples:</p> <ul style="list-style-type: none"> - I respected all the requirements (and we see the canvas with requirements respected) - If they were square they take 3 rows but triangular (or honeycomb) I was able to fit 4 - Space for plants to grow is an estimate - Plants might not need exactly the same space to grow - The price of soil can be less if we buy multiple litres or price of plants can be less if multiple plants

Examples for D0

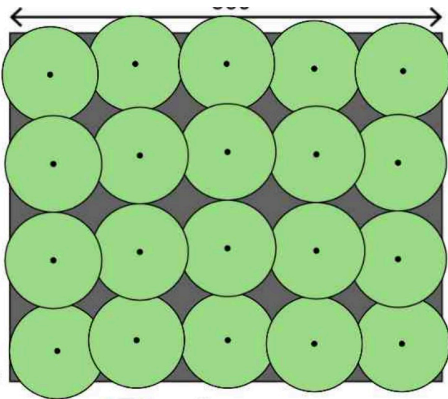
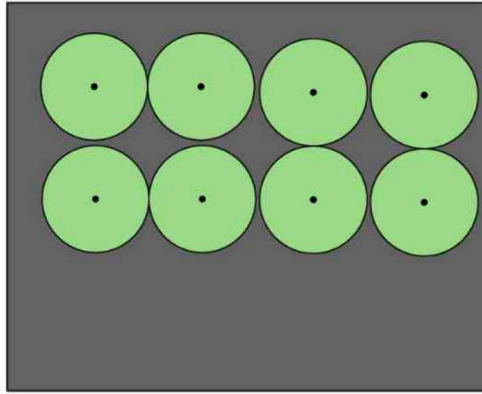
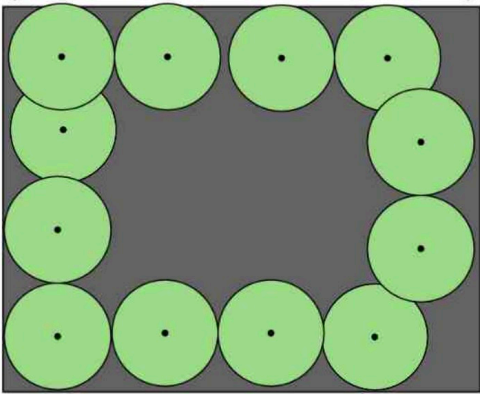

Examples for D1

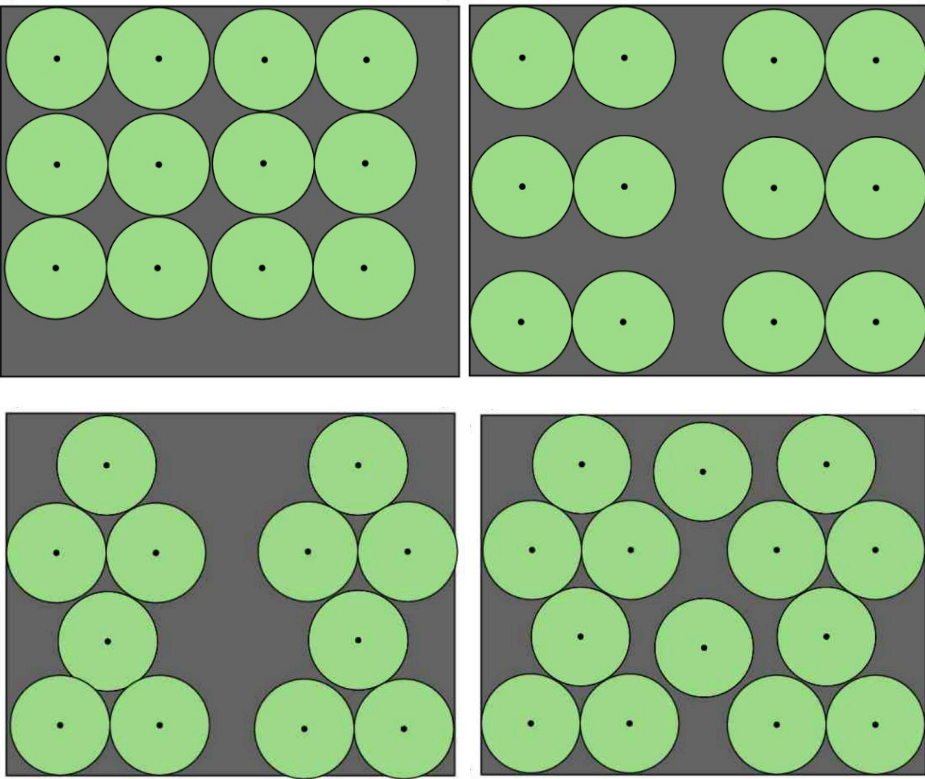

Examples for D2

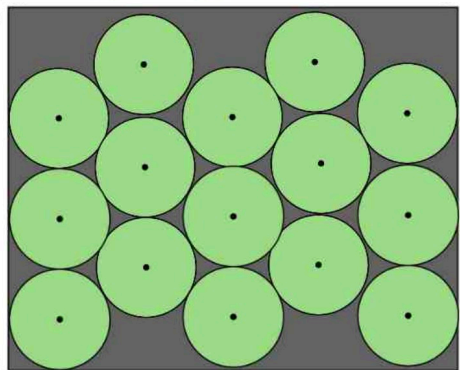
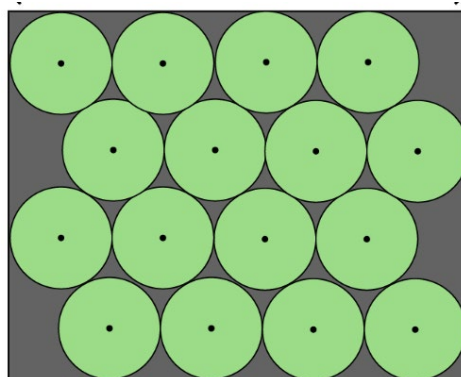
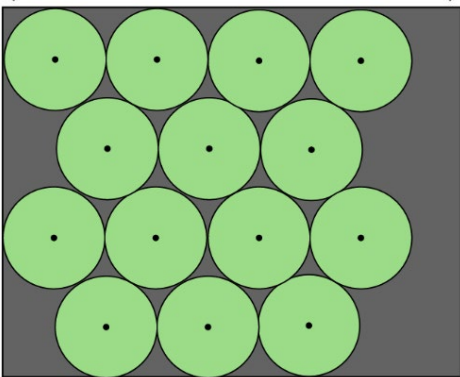

Q8

Glossary for task 3

Term used	Clarification
General rule	Rule in terms of only n (if they use x , it is still general rule but penalise in notation)
The general rule	The correct general rule in terms of only n (if they use x , it is still the general rule but penalise in notation)
Their general rule	valid attempt for the general rule but in terms of only n (if they use x , it is still their general rule but penalise in notation)
Their rule	Correct rule not in terms of only n
Recursive rule	

We accept subsequent use of their general rule (when marking D,T, V,J, N, and L) provided it is of similar complexity. In general, the complexity of the rule depends on its form. The table below shows examples.

The general rule	ACCEPT for their general rule	DO NOT ACCEPT for their general rule
$4n$	Linear	
n^2+5n	Quadratic or exponential	Linear

Q8	Answers	Notes	Total	
a	Correctly place 20 and 24	5	20	1
		6	24	
b	.1 correctly describe one pattern for S in words .2 correctly describe a second pattern for S in words	<p>ACCEPT complete terminology only, for example (below are four different descriptions)</p> <ul style="list-style-type: none"> > divisible by 4, multiples of 4, timetable of 4 > Increasing by 4, adds 4, goes up by 4, moving up by 4, difference 4, common difference 4, linear with difference 4, arithmetic with difference 4 > Even numbers > Second difference zero <p>DO NOT ACCEPT general descriptions or incorrect descriptions for example: Integers, whole numbers, positive, divisible by 2, multiples of 2, or the even numbers</p> <p>DO NOT ACCEPT general description, for example: Integers, whole numbers, positive, even numbers, divisible by 2, multiples of 2</p> <p>DO NOT ACCEPT the rule in words or description related to n for example: 4 times n, n multiplied by 4, WTTE</p> <p>Note, in the case when they have more than two different patterns: If two are accepted award 2 marks If one is accepted award 1 mark</p>	2	

<p>c</p>	<p>.1 the correct general rule .2 the correct simplified general rule with correct notation for S in terms of n.</p>	<p>.1 $4n$ or $S=4xn$ $S=4*n$.2 $S = 4n$.2 ACCEPT using Sn instead of S .2 ACCEPT $S = n4$.2 ACCEPT using s and N DO NOT ACCEPT description in words</p>	<p>2</p>
<p>d</p>	<p>.1 correctly substitute $n \geq 5$ into their general rule (from 7c or 7b) .2 correctly calculate their value of S after substituting $n \geq 5$.3 recognise that their correctly calculated value of S is the same as their predicted value</p>	<p>.1 Ex: 4×5 .2 Ex: 20 (for $n = 5$) .3 If they use $n=5$ or $n=6$ ACCEPT only if they say "as seen in the table" WTTE or we see the predicted values re-written here in part d) .3 If they use $n > 6$ ACCEPT only if they say "the same as when we continue the pattern" WTTE and state how. Ex: for $n=7$, 24 is obtained from pattern of adding 4 to 24</p>	<p>3</p>
<p>e</p>	<p>Correct combination of numbers, based on the diagram, that lead to 20</p>	<p>2×10 or $10 + 10$ or $(4 + 3 + 2 + 1) \times 2$ ACCEPT any of the above explained in words ACCEPT $6 \times 10 - 6 \times 4 - 16$ DO NOT ACCEPT $36 - 16$ or 4×5 or 1×20 DO NOT ACCEPT substituting into the general rule in terms of n; $4^2 + 4$</p>	<p>1</p>

Q8f 22 marks

Table Object			
Stage number (n)	Area of striped faces (S)	Area of plain faces (P)	Total surface area (A)
1	4	2	6
2	8	6	14
3	12	12	24
4	16	20	36
5	20	30	50
6	24	42	66
7	28	56	84

Mark	1	2
Predictions (P)	Correctly predict two terms for P OR Correctly predict one term for A	Correctly predict two terms for A
	Ignore additional incorrect predictions	Ignore additional incorrect predictions

Mark	1	2	3	4	5	
Description (D) ACCEPT incorrect terminologies, notation errors, non-simplified rule, or rule in words but penalize in notation (N) Ignore additional incorrect patterns	Correctly describe a pattern in words for A Examples of different patterns: The increase, or the difference, is even or multiple of 2 The increase, or the difference, increases by 2 Second difference 2 ACCEPT "Second difference constant" only if their working shows second difference is 2 ACCEPT patterns described with incorrect terminologies but penalise in notation (N). Ex: $(T=)T+2n+2$ or $X=X+2n+2$ or the rule is $T+2n+2$ DO NOT ACCEPT increasing DO NOT ACCEPT Even numbers Seeing only Quadratic Correct pattern in words for P $A=S+P$	Correctly describe a pattern in words for A AND Their general rule for P as a <u>quadratic</u> satisfying at least one value for n OR their general rule for A as exponential satisfying at least one value for n	Correctly describe a pattern in words for A AND Their general rule for A as a <u>quadratic</u> satisfying at least one value for n or correct recursive rule for A	Correctly describe a pattern in words or recursive rule for A AND The general rule for P	Correctly describe one pattern in words or correct recursive rule for A AND The general rule for A	
	OR Their general rule for P as a <u>quadratic</u> satisfying at least one value for n	OR Their general rule for A as a <u>quadratic</u> satisfying at least one values for n	OR The general rule for P $(P=) n(n+1)$ OE	OR The general rule for A $(A =)n^2 + 5n$ OE		
		OR Correct recursive rule for A $(A_n) = A_{n-1} + 2n + 4$	OR The general rule for P in words or partially in words	OR The general rule for A in words or partially in words		

Mark	1	2
Testing (T)	Attempt to test their general rule for A using $n \leq 4$ Ex: Correctly substitute in their general rule for A value of $n \leq 4$	Correctly test their general rule for A using $n \leq 4$ Ex: correctly calculate their value for A in their general rule for A using $n \leq 4$ AND Recognise that <u>their</u> correctly calculated value for A is the same as <u>the</u> given value in the table
	OR Correctly test their described pattern or their rule (ex: recursive rule or their linear rule for A)	ACCEPT Seeing their correctly calculated value for A as fraction or decimal, and the given value in the table being equal

	1	2	3
Verifying (V)	Attempt to verify their general rule for A using $n \geq 5$ Ex: Correctly substitute in their general rule for A value of $n \geq 5$	Correctly calculate their value for A in their general rule for A using $n \geq 5$	ACCEPT only if they have <u>the</u> general rule for A
	OR Correctly verify their described pattern or their rule (ex: recursive rule or their linear rule for A)		Correctly calculate their value for A in <u>the general rule</u> using $n \geq 5$ AND Recognise that <u>the</u> correctly calculated value for A is the same as <u>the</u> correct predicted value for A obtained by continuing the pattern ACCEPT if the correctly calculated value is the same as the one in the table

Mark	1	2	3	4
Justify/ proof (J)	ACCEPT only if D1 is achieved	ACCEPT only if D2 is achieved	ACCEPT only if they have <u>the</u> general rule for A	ACCEPT only if they have <u>the</u> general rule for A
	Attempt to justify <u>their</u> general rule for A Ex: Quadratic model and valid attempt to find values of coefficients using any method.	Attempt to justify: $n^2 + 5n$ OE Ex: Quadratic model and find the correct values of coefficients using any method	Good attempt to justify <u>the</u> general rule for A geometrically Use the sum of correct rules for S and P but without simplification Ex: $A = n(n + 1) + 4n$	Correctly justify <u>the</u> general rule for A geometrically Use the sum of correct S and P rules <u>with complete simplification</u> : They show how the sum of the correct S and P rules simplifies to
	OR Weak attempt to justify <u>their</u> general rule for A geometrically by realizing two sequences are added Ex: write $A=S+P$ <u>and</u> substitute numbers Ex: $A=S+P$ <u>and</u> they say as seen in the table WTTE Ex: Explain in words	OR Weak attempt to justify <u>their</u> general rule for A by realizing their sequence S (in terms of n) is added to their sequence P (in terms of n)		$n^2 + 5n$ Ex: $n(n + 1) + 4n = n^2 + n + 4n = n^2 + 5n$
	OR Substitute at least two <u>other</u> values of n in their general rule for A <u>and</u> say they are the same or it works WTTE			
OR Attempt to justify: $(P =)n^2 + n$ OE Ex: Quadratic model and find the correct values of coefficients using any method				

Mark	1	2	3
Notation and terminology (N) Ignore additional incorrect patterns	ACCEPT only if D1 achieved	ACCEPT only if they have <u>the</u> general rule for A	ACCEPT only if they have <u>the</u> general rule for A
	Correctly describe one pattern for A in words <u>using correct terminology</u> or correct recursive rule for A using correct notation Example: Second difference is the same ACCEPT what we add increases by 2 DO NOT ACCEPT what goes up adds 2, the increase plusses 2 DO NOT ACCEPT if the pattern is not accepted in D1	Correctly describe one pattern for A in words <u>using correct terminology</u> (see examples in N1) <u>and</u> the notation of <u>the general</u> rule for A includes errors or not simplified or in words (see examples in N1)	Correctly describe one pattern for A in words <u>using correct terminology</u> (see examples in N1)
	OR The notation of <u>the general</u> rule for A includes errors or not simplified or in words. Examples: $A = n^2 + 5n$ or $A = 1n^2 + 5n$ The rule for A is $n^2 + 5n$	OR Correct notation of <u>the general</u> rule for A in simplest form $A = n^2 + 5n$ or $A = n(n+5)$	AND
	The general rule in words	ACCEPT using A_n or An or $A(n)$ instead of A	Correct notation of <u>the general</u> rule for A in simplest form (see examples in N2)
	OR Correct notation of <u>their</u> general rule for A. Examples: $A = n^2 + 5$ or $A = 4n^2 + 7$ or $A = 2^n$ ACCEPT if not simplified.		
The following are considered errors in notation using * for multiplication, using / for division , using \wedge for power, using x instead of n using U_n instead of A without mentioning that $A = U_n$			

Mark	1	2	3
<p>Communication (L)</p> <p>Organisation and coherence Can be awarded even if there are errors</p> <p>For items: Describing pattern and writing rule can be considered an item even if D0 awarded</p>	<p>At least three from the following items are seen:</p> <ul style="list-style-type: none"> describe a pattern in words write a rule test their general rule or rule or recursive rule or pattern (at least T1) verify their general rule or rule or recursive rule or pattern (at least V1) justify their general rule or rule or recursive rule or pattern (at least J1) 	<p>ACCEPT only if they have their general rule for A</p> <p>At least four of the following items are seen:</p> <ul style="list-style-type: none"> describe a pattern in words write a general rule test their general rule (at least T1) verify their general rule (at least V1) justify their general rule (at least J1) <p>AND</p> <p>For coherence, they identify the processes correctly.</p> <p>At least one from the following:</p> <ul style="list-style-type: none"> test verify justify <p>Ex:</p> <ul style="list-style-type: none"> For test: they say "test" and they substitute in their general rule value(s) of $n \leq 4$ only For verify: they say "verify" and they substitute in their general rule value(s) of $n \geq 5$ only For justify: They say "justify" and they write a justification <p>Note for coherence: If they say "test and verify" and they substitute in their general rule value(s) of $n \leq 4$ <u>followed by</u> value(s) of $n \geq 5$, consider it as only one identified process</p>	<p>ACCEPT only if they have the general rule for A</p> <p>The following two items must be seen :</p> <ul style="list-style-type: none"> write <u>the general rule for A</u> justify <u>the general rule</u> (at least J2) <p>AND</p> <p>At least two of the following items are seen:</p> <ul style="list-style-type: none"> describe a pattern or rule in words test <u>the general rule</u> (at least T1) verify <u>the general rule</u> (at least V1) <p>AND</p> <p>For coherence, they identify the processes correctly.</p> <p>At least two from the following:</p> <ul style="list-style-type: none"> test verify justify <p>Ex:</p> <ul style="list-style-type: none"> For test: they say "test" and they substitute in the general rule for A value(s) of $n \leq 4$ only For verify: they say "verify" and they substitute in the general rule for A value(s) of $n \geq 5$ only For justify: They say "justify" and they write a justification <p>Note for coherence: If they say "test and verify" and they substitute in the general rule value(s) of $n \leq 4$ <u>followed by</u> value(s) of $n \geq 5$, consider it as only one identified process</p>

