

© International Baccalaureate Organization 2021

All rights reserved. No part of this product may be reproduced in any form or by any electronic or mechanical means, including information storage and retrieval systems, without the prior written permission from the IB. Additionally, the license tied with this product prohibits use of any selected files or extracts from this product. Use by third parties, including but not limited to publishers, private teachers, tutoring or study services, preparatory schools, vendors operating curriculum mapping services or teacher resource digital platforms and app developers, whether fee-covered or not, is prohibited and is a criminal offense.

More information on how to request written permission in the form of a license can be obtained from <https://ibo.org/become-an-ib-school/ib-publishing/licensing/applying-for-a-license/>.

© Organisation du Baccalauréat International 2021

Tous droits réservés. Aucune partie de ce produit ne peut être reproduite sous quelque forme ni par quelque moyen que ce soit, électronique ou mécanique, y compris des systèmes de stockage et de récupération d'informations, sans l'autorisation écrite préalable de l'IB. De plus, la licence associée à ce produit interdit toute utilisation de tout fichier ou extrait sélectionné dans ce produit. L'utilisation par des tiers, y compris, sans toutefois s'y limiter, des éditeurs, des professeurs particuliers, des services de tutorat ou d'aide aux études, des établissements de préparation à l'enseignement supérieur, des fournisseurs de services de planification des programmes d'études, des gestionnaires de plateformes pédagogiques en ligne, et des développeurs d'applications, moyennant paiement ou non, est interdite et constitue une infraction pénale.

Pour plus d'informations sur la procédure à suivre pour obtenir une autorisation écrite sous la forme d'une licence, rendez-vous à l'adresse <https://ibo.org/become-an-ib-school/ib-publishing/licensing/applying-for-a-license/>.

© Organización del Bachillerato Internacional, 2021

Todos los derechos reservados. No se podrá reproducir ninguna parte de este producto de ninguna forma ni por ningún medio electrónico o mecánico, incluidos los sistemas de almacenamiento y recuperación de información, sin la previa autorización por escrito del IB. Además, la licencia vinculada a este producto prohíbe el uso de todo archivo o fragmento seleccionado de este producto. El uso por parte de terceros —lo que incluye, a título enunciativo, editoriales, profesores particulares, servicios de apoyo académico o ayuda para el estudio, colegios preparatorios, desarrolladores de aplicaciones y entidades que presten servicios de planificación curricular u ofrezcan recursos para docentes mediante plataformas digitales—, ya sea incluido en tasas o no, está prohibido y constituye un delito.

En este enlace encontrará más información sobre cómo solicitar una autorización por escrito en forma de licencia: <https://ibo.org/become-an-ib-school/ib-publishing/licensing/applying-for-a-license/>.

Physics
Higher level
Paper 1

Monday 3 May 2021 (afternoon)

1 hour

Instructions to candidates

- Do not open this examination paper until instructed to do so.
- Answer all the questions.
- For each question, choose the answer you consider to be the best and indicate your choice on the answer sheet provided.
- A clean copy of the **physics data booklet** is required for this paper.
- The maximum mark for this examination paper is **[40 marks]**.

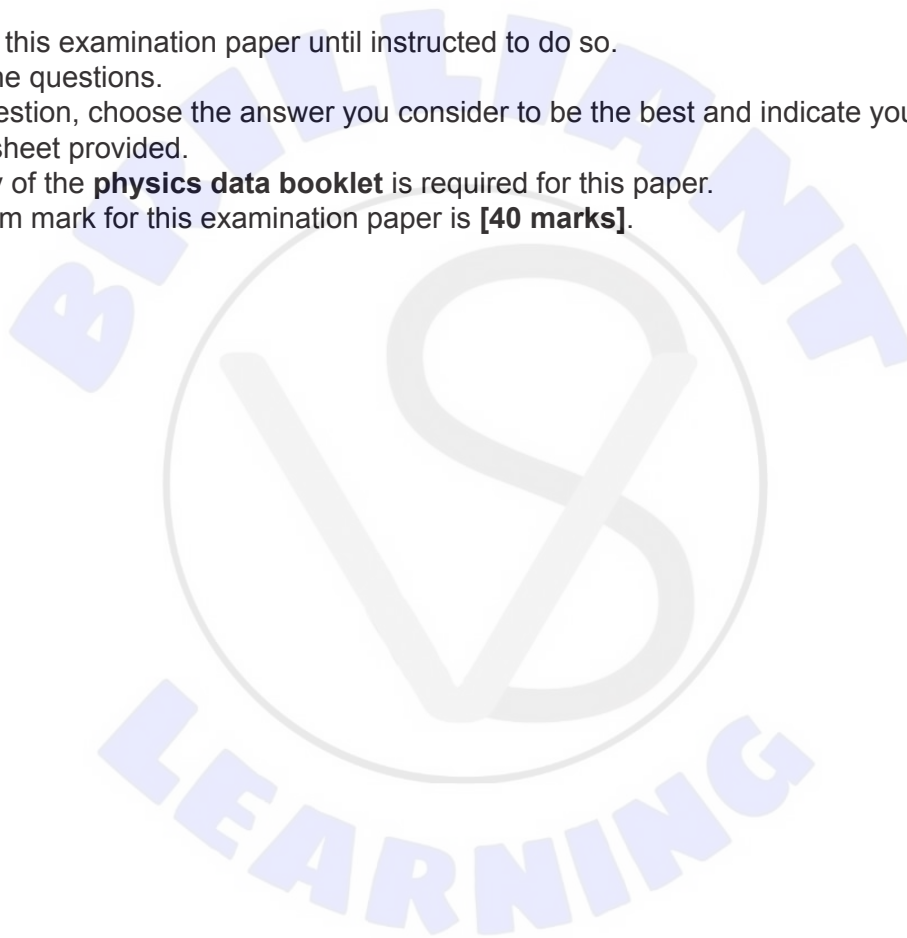

1. A student measures the length l and width w of a rectangular table top.

What is the absolute uncertainty of the perimeter of the table top?

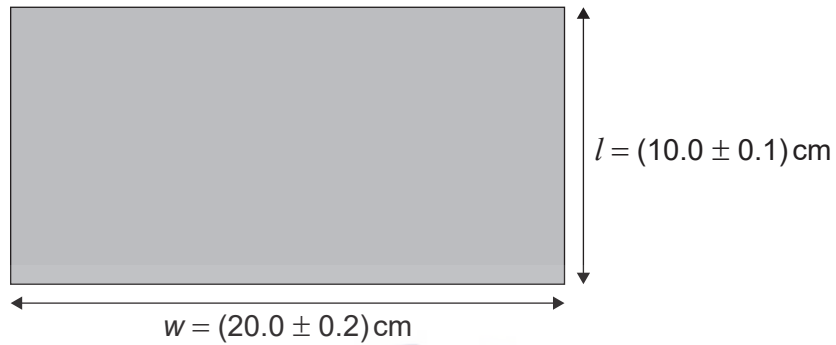

- A. 0.3 cm
 - B. 0.6 cm
 - C. 1.2 cm
 - D. 2.4 cm
2. The minute hand of a clock hanging on a vertical wall has length $L = 30 \text{ cm}$.



The minute hand is observed pointing at 12 and then again 30 minutes later when the minute hand is pointing at 6.

(This question continues on the following page)

(Question 2 continued)

What is the average velocity and average speed of point P on the minute hand during this time interval?

	Average velocity	Average speed
A.	2 cm min ⁻¹ vertically downwards	π cm min ⁻¹
B.	2 cm min ⁻¹ vertically upwards	π cm min ⁻¹
C.	2π cm min ⁻¹ vertically downwards	2π cm min ⁻¹
D.	2π cm min ⁻¹ vertically upwards	2π cm min ⁻¹

3. A block rests on a rough horizontal plane. A force P is applied to the block and the block moves to the right.



There is a coefficient of friction μ_d giving rise to a frictional force F between the block and the plane. The force P is doubled. Will μ_d and F be unchanged or greater?

	μ_d	F
A.	unchanged	unchanged
B.	unchanged	greater
C.	greater	greater
D.	greater	unchanged

Turn over

4. A projectile is launched at an angle above the horizontal with a horizontal component of velocity V_h and a vertical component of velocity V_v . Air resistance is negligible. Which graphs show the variation with time of V_h and of V_v ?

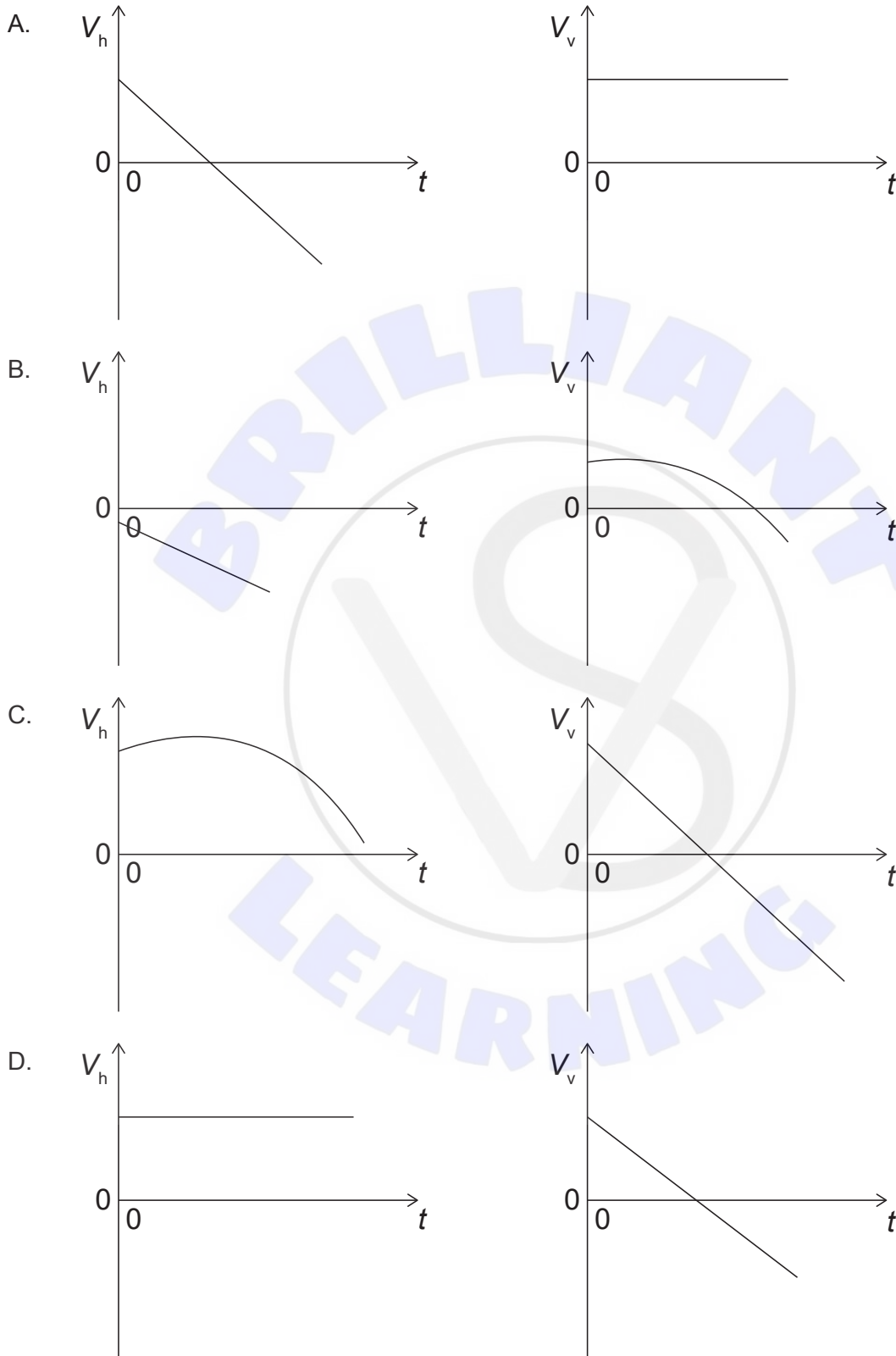

5. A person with a weight of 600 N stands on a scale in an elevator.

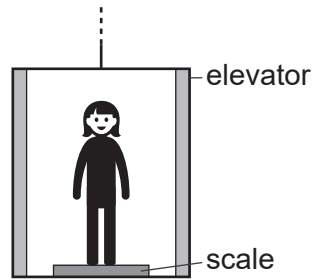

What is the acceleration of the elevator when the scale reads 900 N?

- A. 5.0 ms^{-2} downwards
 - B. 1.5 ms^{-2} downwards
 - C. 1.5 ms^{-2} upwards
 - D. 5.0 ms^{-2} upwards
6. Two identical blocks, each of mass m and speed v , travel towards each other on a frictionless surface.



The blocks undergo a head-on collision. What is definitely true **immediately** after the collision?

- A. The momentum of each block is zero.
- B. The total momentum is zero.
- C. The momentum of each block is $2mv$.
- D. The total momentum is $2mv$.

Turn over

7. The graph shows the variation with distance of a horizontal force acting on an object. The object, initially at rest, moves horizontally through a distance of 50 m.

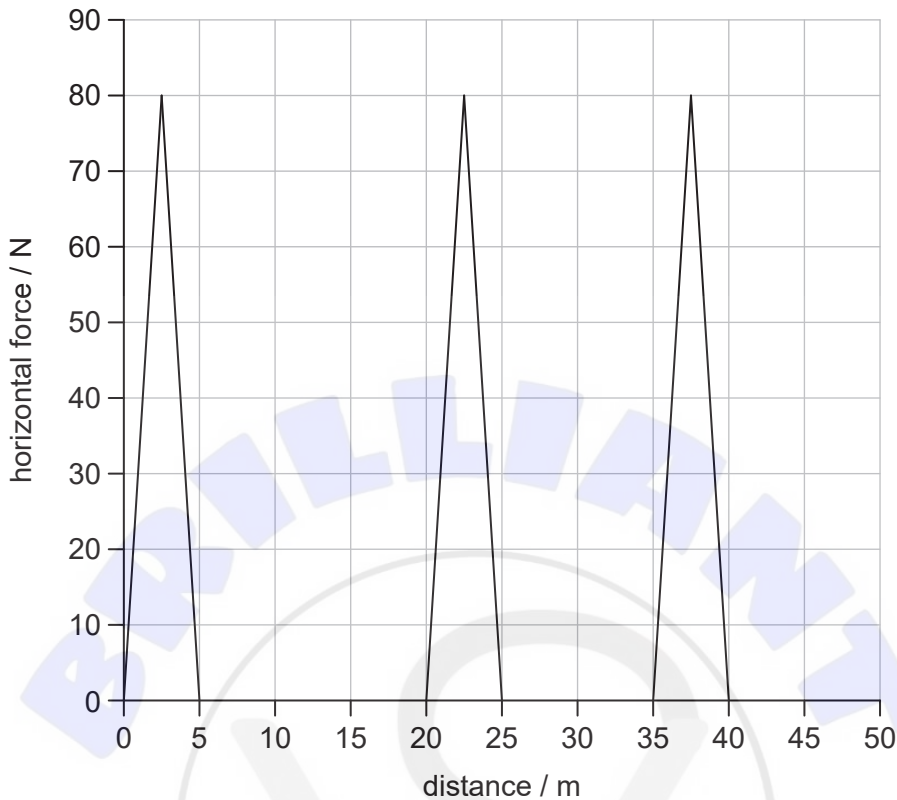

A constant frictional force of 2.0 N opposes the motion. What is the final kinetic energy of the object after it has moved 50 m?

- A. 100 J
 - B. 500 J
 - C. 600 J
 - D. 1100 J
8. A sample of oxygen gas with a volume of 3.0 m^3 is at 100°C . The gas is heated so that it expands at a constant pressure to a final volume of 6.0 m^3 . What is the final temperature of the gas?
- A. 750°C
 - B. 470°C
 - C. 370°C
 - D. 200°C

9. Two identical containers X and Y each contain an ideal gas. X has N molecules of gas at an absolute temperature of T and Y has $3N$ molecules of gas at an absolute temperature of $\frac{T}{2}$. What is the ratio of the pressures $\frac{P_Y}{P_X}$?

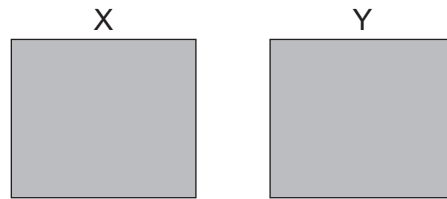

- A. $\frac{1}{6}$
B. $\frac{2}{3}$
C. $\frac{3}{2}$
D. 6
10. A piece of metal at a temperature of 100°C is dropped into an equal mass of water at a temperature of 15°C in a container of negligible mass. The specific heat capacity of water is four times that of the metal. What is the final temperature of the mixture?
- A. 83°C
B. 57°C
C. 45°C
D. 32°C
11. The bob of a pendulum has an initial displacement x_0 to the right. The bob is released and allowed to oscillate. The graph shows how the displacement varies with time. At which point is the velocity of the bob at its maximum magnitude directed towards the left?

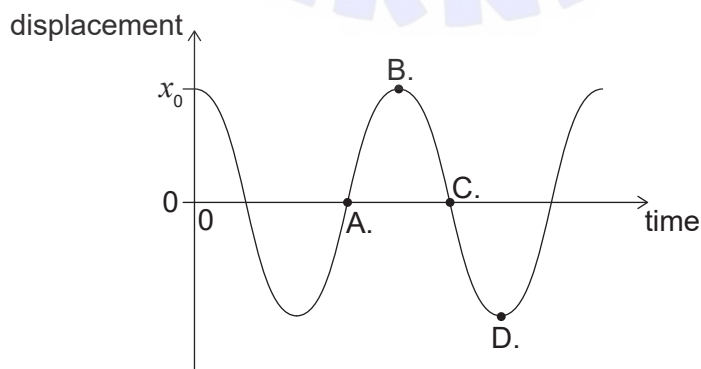

Turn over

12. Which graph shows the variation of amplitude with intensity for a wave?

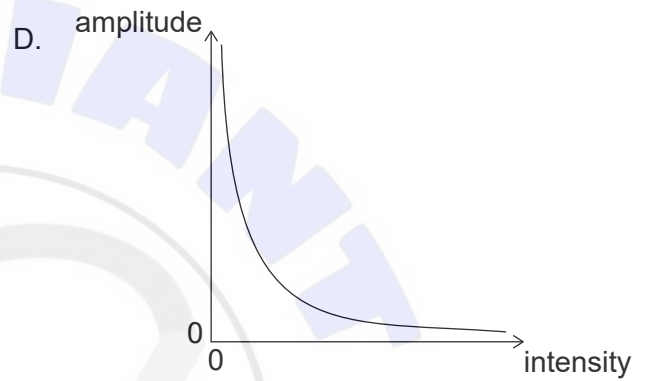
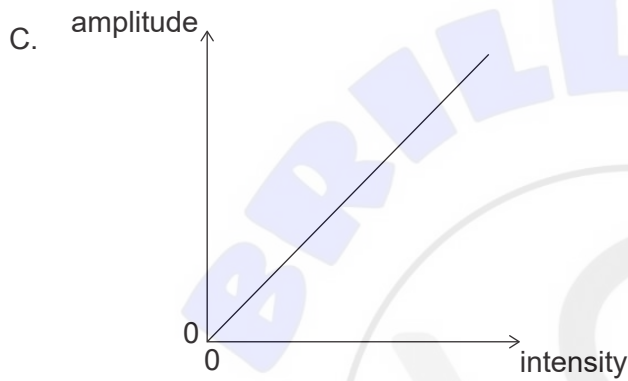
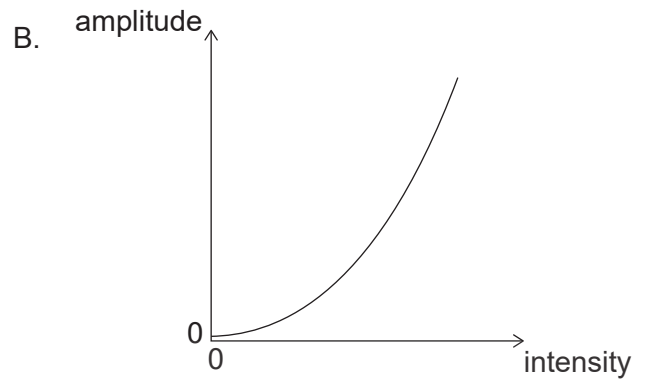
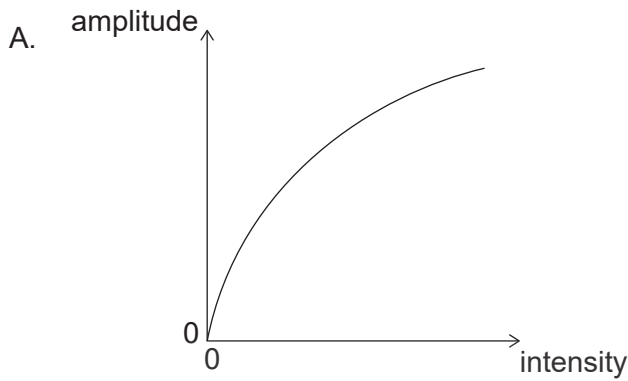

13. Unpolarized light of intensity I_1 is incident on a polarizer. The light that passes through this polarizer then passes through a second polarizer.

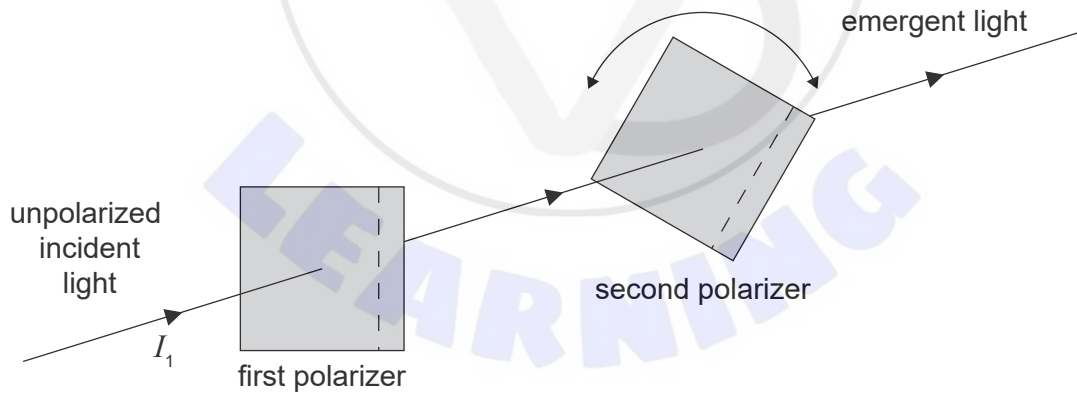

The second polarizer can be rotated to vary the intensity of the emergent light. What is the maximum value of the intensity emerging from the second polarizer?

- A. $\frac{I_1}{4}$
- B. $\frac{I_1}{2}$
- C. $\frac{2I_1}{3}$
- D. I_1

14. The frequency of the first harmonic in a pipe is measured. An adjustment is then made which causes the speed of sound in the pipe to increase. What is true for the frequency and the wavelength of the first harmonic when the speed of sound has increased?

	Frequency	Wavelength
A.	increase	unchanged
B.	unchanged	increase
C.	increase	increase
D.	unchanged	unchanged

15. The diagram shows two cylindrical wires, X and Y. Wire X has a length l , a diameter d , and a resistivity ρ . Wire Y has a length $2l$, a diameter of $\frac{d}{2}$ and a resistivity of $\frac{\rho}{2}$.

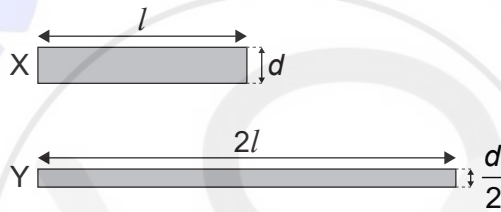

What is $\frac{\text{resistance of X}}{\text{resistance of Y}}$?

- A. 4
 B. 2
 C. 0.5
 D. 0.25
16. An ion moves in a circle in a uniform magnetic field. Which single change would increase the radius of the circular path?
- A. Decreasing the speed of the ion
 B. Increasing the charge of the ion
 C. Increasing the mass of the ion
 D. Increasing the strength of the magnetic field

Turn over

17. A circuit contains a variable resistor of maximum resistance R and a fixed resistor, also of resistance R , connected in series. The emf of the battery is 6.0V and its internal resistance is negligible.

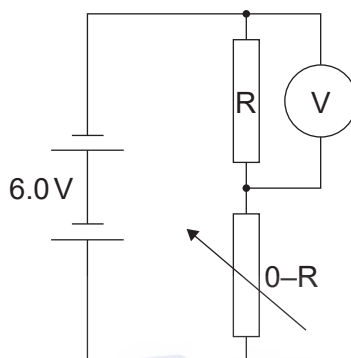

What are the initial and final voltmeter readings when the variable resistor is increased from an initial resistance of zero to a final resistance of R ?

	Initial voltmeter reading / V	Final voltmeter reading / V
A.	0	6.0
B.	6.0	0
C.	6.0	3.0
D.	3.0	6.0

18. Magnetic field lines are an example of
- a discovery that helps us understand magnetism.
 - a model to aid in visualization.
 - a pattern in data from experiments.
 - a theory to explain concepts in magnetism.
19. An object moves in a circle of constant radius. Values of the centripetal force F are measured for different values of angular velocity ω . A graph is plotted with ω on the x -axis. Which quantity plotted on the y -axis will produce a straight-line graph?
- \sqrt{F}
 - F
 - F^2
 - $\frac{1}{F}$

20. A sample of a pure radioactive nuclide initially contains N_0 atoms. The initial activity of the sample is A_0 .

A second sample of the same nuclide initially contains $2N_0$ atoms.

What is the activity of the second sample after three half lives?

- A. $\frac{A_0}{2}$
 - B. $\frac{A_0}{4}$
 - C. $\frac{A_0}{6}$
 - D. $\frac{A_0}{8}$
21. The diagram below shows four energy levels for the atoms of a gas. The diagram is drawn to scale. The wavelengths of the photons emitted by the energy transitions between levels are shown.



What are the wavelengths of spectral lines, emitted by the gas, in order of decreasing frequency?

- A. $\lambda_3, \lambda_2, \lambda_1, \lambda_4$
- B. $\lambda_4, \lambda_1, \lambda_2, \lambda_3$
- C. $\lambda_4, \lambda_3, \lambda_2, \lambda_1$
- D. $\lambda_4, \lambda_2, \lambda_1, \lambda_3$

Turn over

22. During the nuclear fission of nucleus X into nucleus Y and nucleus Z, energy is released. The binding energies per nucleon of X, Y and Z are B_X , B_Y and B_Z respectively. What is true about the binding energy per nucleon of X, Y and Z?

- A. $B_Y > B_X$ and $B_Z > B_X$
- B. $B_X = B_Y$ and $B_X = B_Z$
- C. $B_X > B_Y$ and $B_X > B_Z$
- D. $B_X = B_Y + B_Z$

23. Consider the Feynman diagram below.

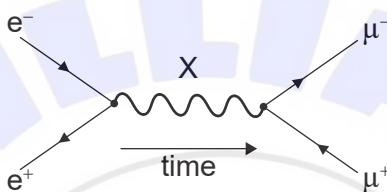

What is the exchange particle X?

- A. Lepton
 - B. Gluon
 - C. Meson
 - D. Photon
24. What is the main role of carbon dioxide in the greenhouse effect?
- A. It absorbs incoming radiation from the Sun.
 - B. It absorbs outgoing radiation from the Earth.
 - C. It reflects incoming radiation from the Sun.
 - D. It reflects outgoing radiation from the Earth.

25. A model of an ideal wind turbine with blade length l_0 is designed to produce a power P when the average wind speed is v . A second ideal wind turbine is designed to produce a power $\frac{P}{2}$ when the average wind speed is $\frac{v}{2}$. What is the blade length for the second wind turbine?
- A. $\frac{l_0}{2}$
 B. l_0
 C. $2l_0$
 D. $4l_0$
26. A mass–spring system oscillates vertically with a period of T at the surface of the Earth. The gravitational field strength at the surface of Mars is $0.3g$. What is the period of the same mass–spring system on the surface of Mars?
- A. $0.09T$
 B. $0.3T$
 C. T
 D. $3T$
27. Light passes through a diffraction grating. Which quantity must be decreased to improve the resolution of the diffraction grating?
- A. The grating spacing
 B. The number of grating lines illuminated by the light source
 C. The number of grating lines per millimetre
 D. The spectral order being observed
28. A train is moving in a straight line away from a stationary observer when the train horn emits a sound of frequency f_0 . The speed of the train is $0.10v$ where v is the speed of sound. What is the frequency of the horn as heard by the observer?
- A. $\frac{0.9}{1} f_0$
 B. $\frac{1}{1.1} f_0$
 C. $\frac{1.1}{1} f_0$
 D. $\frac{1}{0.9} f_0$

Turn over

29. Monochromatic light of wavelength λ passes through a single-slit of width b and produces a diffraction pattern on a screen. Which combination of changes to b and λ will cause the greatest decrease in the width of the central maximum?

	Slit width	Wavelength of light
A.	$\frac{1}{2}b$	$\frac{1}{2}\lambda$
B.	$\frac{1}{2}b$	2λ
C.	$2b$	$\frac{1}{2}\lambda$
D.	$2b$	2λ

30. An object of mass m released from rest near the surface of a planet has an initial acceleration z . What is the gravitational field strength near the surface of the planet?

- A. z
 B. $\frac{z}{m}$
 C. mz
 D. $\frac{m}{z}$

31. The points X and Y are in a uniform electric field of strength E . The distance OX is x and the distance OY is y .

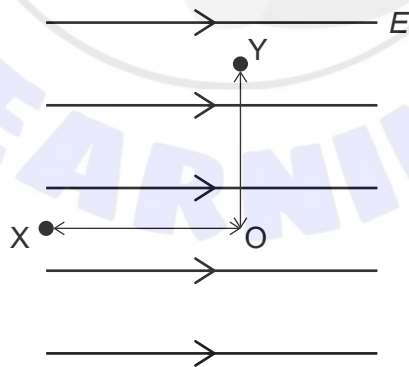

What is the magnitude of the change in electric potential between X and Y?

- A. E_x
 B. E_y
 C. $E(x + y)$
 D. $E\sqrt{x^2 + y^2}$

32. A satellite orbits planet X with a speed v_x at a distance r from the centre of planet X. Another satellite orbits planet Y at a speed of v_y at a distance r from the centre of planet Y. The mass of planet X is M and the mass of planet Y is $4M$. What is the ratio of $\frac{v_x}{v_y}$?

- A. 0.25
- B. 0.5
- C. 2.0
- D. 4.0

33. A parallel-plate capacitor is connected to a cell of constant emf. The capacitor plates are then moved closer together without disconnecting the cell. What are the changes in the capacitance of the capacitor and the energy stored in the capacitor?

	Capacitance	Energy
A.	increases	increases
B.	increases	decreases
C.	decreases	decreases
D.	decreases	increases

34. The graph shows the variation of an alternating current with time in a 4.0Ω resistor.

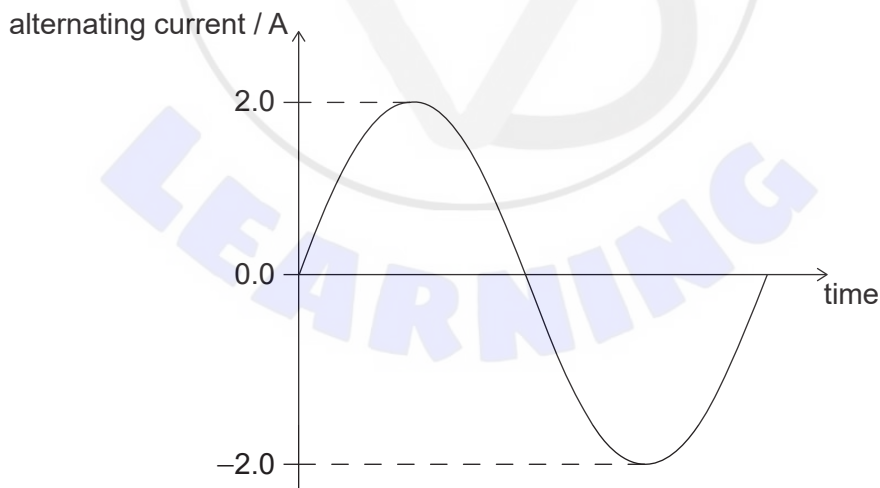

What is the average power dissipated in the resistor?

- A. 4W
- B. 8W
- C. 16W
- D. 32W

Turn over

35. A magnet connected to a spring oscillates above a solenoid with a 240 turn coil as shown.

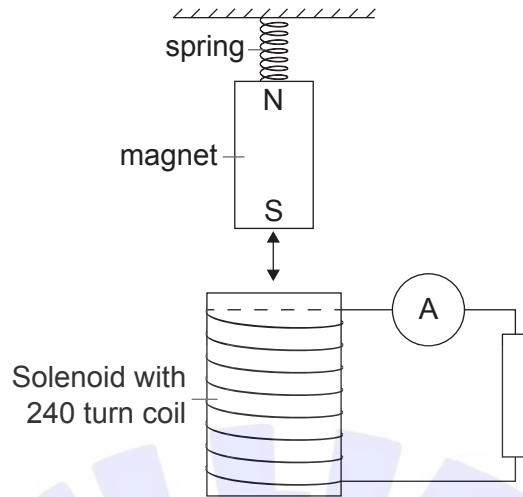

The graph below shows the variation with time t of the emf across the solenoid with the period, T , of the system shown.

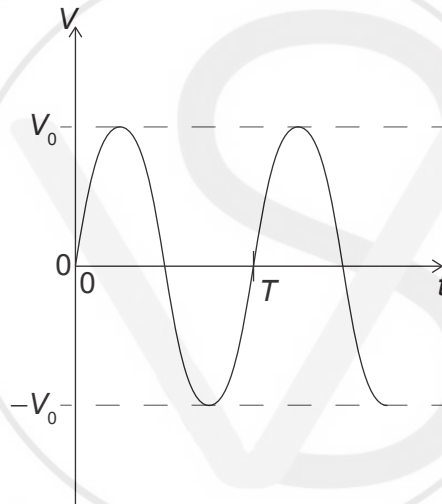

(This question continues on the following page)

(Question 35 continued)

The spring is replaced with one that allows the magnet to oscillate with a higher frequency. Which graph shows the new variation with time t of the current I in the resistor for this new set-up?

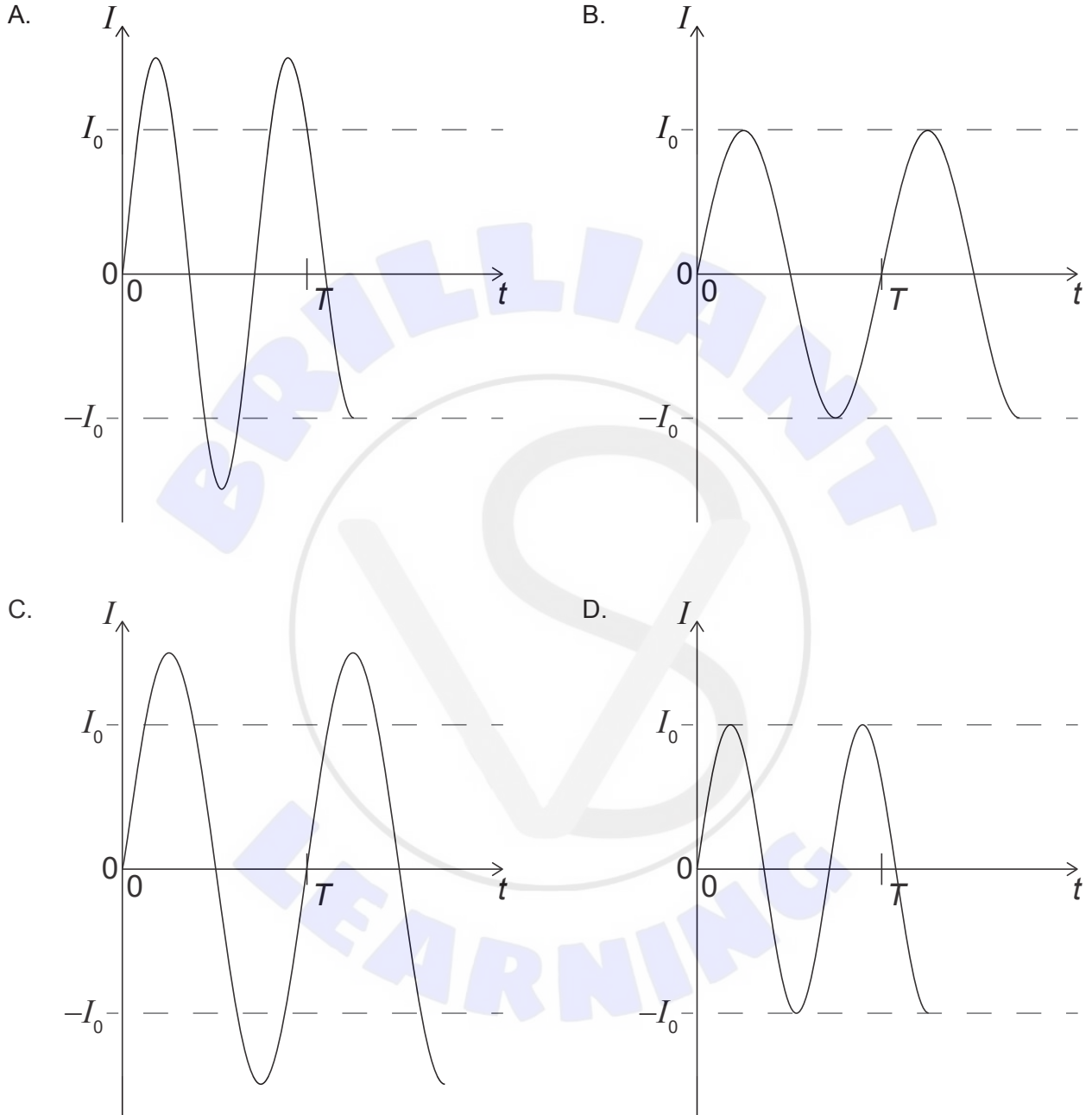

Turn over

36. A capacitor is charged with a constant current I . The graph shows the variation of potential difference V across the capacitor with time t . The gradient of the graph is G . What is the capacitance of the capacitor?

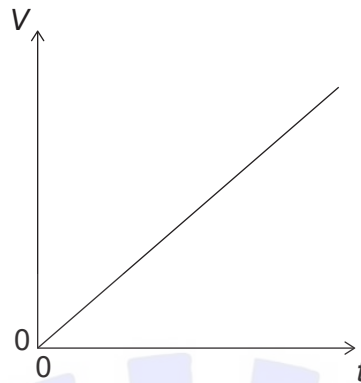

- A. $\frac{I}{G}$
 B. $\frac{G}{I}$
 C. $G \times I$
 D. $\frac{1}{G \times I}$
37. A particle of energy E is incident upon a barrier and has a certain probability of quantum tunnelling through the barrier. Assuming E remains constant, which combination of changes in particle mass and barrier length will increase the probability of the particle tunnelling through the barrier?

	Particle mass	Barrier length
A.	decrease	decrease
B.	increase	decrease
C.	decrease	increase
D.	increase	increase

38. Element X has a nucleon number A_x and a nuclear density ρ_x . Element Y has a nucleon number of $2A_x$. What is an estimate of the nuclear density of element Y?

- A. $\frac{1}{2}\rho_x$
 B. ρ_x
 C. $2\rho_x$
 D. $8\rho_x$

39. What is true for the Bohr model for the hydrogen atom?
- A. Angular momentum of electrons is quantized.
 - B. Electrons are described by wave functions.
 - C. Electrons never exist in fixed orbitals.
 - D. Electrons will continuously emit radiation.
40. An electron of non-relativistic speed v interacts with an atom. All the energy of the electron is transferred to an emitted photon of frequency f . An electron of speed $2v$ now interacts with the same atom and all its energy is transmitted to a second photon. What is the frequency of the second photon?
- A. $\frac{f}{4}$
 - B. $\frac{f}{2}$
 - C. $2f$
 - D. $4f$
-

References:

© International Baccalaureate Organization 2021