

© International Baccalaureate Organization 2023

All rights reserved. No part of this product may be reproduced in any form or by any electronic or mechanical means, including information storage and retrieval systems, without the prior written permission from the IB. Additionally, the license tied with this product prohibits use of any selected files or extracts from this product. Use by third parties, including but not limited to publishers, private teachers, tutoring or study services, preparatory schools, vendors operating curriculum mapping services or teacher resource digital platforms and app developers, whether fee-covered or not, is prohibited and is a criminal offense.

More information on how to request written permission in the form of a license can be obtained from <https://ibo.org/become-an-ib-school/ib-publishing/licensing/applying-for-a-license/>.

© Organisation du Baccalauréat International 2023

Tous droits réservés. Aucune partie de ce produit ne peut être reproduite sous quelque forme ni par quelque moyen que ce soit, électronique ou mécanique, y compris des systèmes de stockage et de récupération d'informations, sans l'autorisation écrite préalable de l'IB. De plus, la licence associée à ce produit interdit toute utilisation de tout fichier ou extrait sélectionné dans ce produit. L'utilisation par des tiers, y compris, sans toutefois s'y limiter, des éditeurs, des professeurs particuliers, des services de tutorat ou d'aide aux études, des établissements de préparation à l'enseignement supérieur, des fournisseurs de services de planification des programmes d'études, des gestionnaires de plateformes pédagogiques en ligne, et des développeurs d'applications, moyennant paiement ou non, est interdite et constitue une infraction pénale.

Pour plus d'informations sur la procédure à suivre pour obtenir une autorisation écrite sous la forme d'une licence, rendez-vous à l'adresse <https://ibo.org/become-an-ib-school/ib-publishing/licensing/applying-for-a-license/>.

© Organización del Bachillerato Internacional, 2023

Todos los derechos reservados. No se podrá reproducir ninguna parte de este producto de ninguna forma ni por ningún medio electrónico o mecánico, incluidos los sistemas de almacenamiento y recuperación de información, sin la previa autorización por escrito del IB. Además, la licencia vinculada a este producto prohíbe el uso de todo archivo o fragmento seleccionado de este producto. El uso por parte de terceros —lo que incluye, a título enunciativo, editoriales, profesores particulares, servicios de apoyo académico o ayuda para el estudio, colegios preparatorios, desarrolladores de aplicaciones y entidades que presten servicios de planificación curricular u ofrezcan recursos para docentes mediante plataformas digitales—, ya sea incluido en tasas o no, está prohibido y constituye un delito.

En este enlace encontrará más información sobre cómo solicitar una autorización por escrito en forma de licencia: <https://ibo.org/become-an-ib-school/ib-publishing/licensing/applying-for-a-license/>.

Physics

Higher level

Paper 3

2 May 2023

Zone A afternoon | Zone B morning | Zone C morning

Candidate session number

1 hour 15 minutes

--	--	--	--	--	--	--	--	--	--

Instructions to candidates

- Write your session number in the boxes above.
- Do not open this examination paper until instructed to do so.
- Answers must be written within the answer boxes provided.
- A calculator is required for this paper.
- A clean copy of the **physics data booklet** is required for this paper.
- The maximum mark for this examination paper is **[45 marks]**.

Section A	Questions
Answer all questions.	1 – 2

Section B	Questions
Answer all of the questions from one of the options.	
Option A — Relativity	3 – 7
Option B — Engineering physics	8 – 11
Option C — Imaging	12 – 15
Option D — Astrophysics	16 – 20



Section A

Answer **all** questions. Answers must be written within the answer boxes provided.

1. A student investigates the relationship between the pressure in a ball and the maximum force that the ball produces when it rebounds.

A pressure gauge measures a difference Δp between the atmospheric pressure and the pressure in the ball. A force sensor measures the maximum force F_{\max} exerted on it by the ball during the rebound.

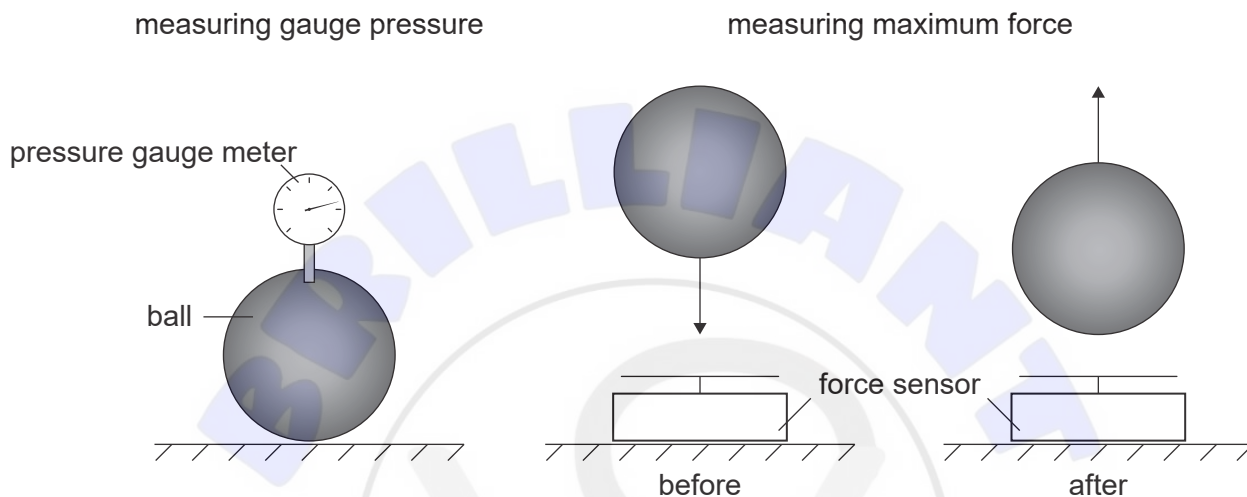

- (a) State **one** variable that needs to be controlled during the investigation. [1]

.....

.....

(This question continues on the following page)



(Question 1 continued)

The student collects the following data.

Gauge pressure Δp / kPa	Maximum force F_{\max} / N
10	108
20	133
30	158
40	170
50	188
60	192
70	206
80	220

The student initially hypothesizes that F_{\max} is proportional to Δp .

- (b) Deduce, using **two** suitable data points from the table, that the student's initial hypothesis is not supported.

[3]

.....

.....

.....

.....

.....

.....

(This question continues on the following page)



(Question 1 continued)

The student now proposes that $F_{\max}^3 = k\Delta p$.

The student plots a graph of the variation of F_{\max}^3 with Δp .

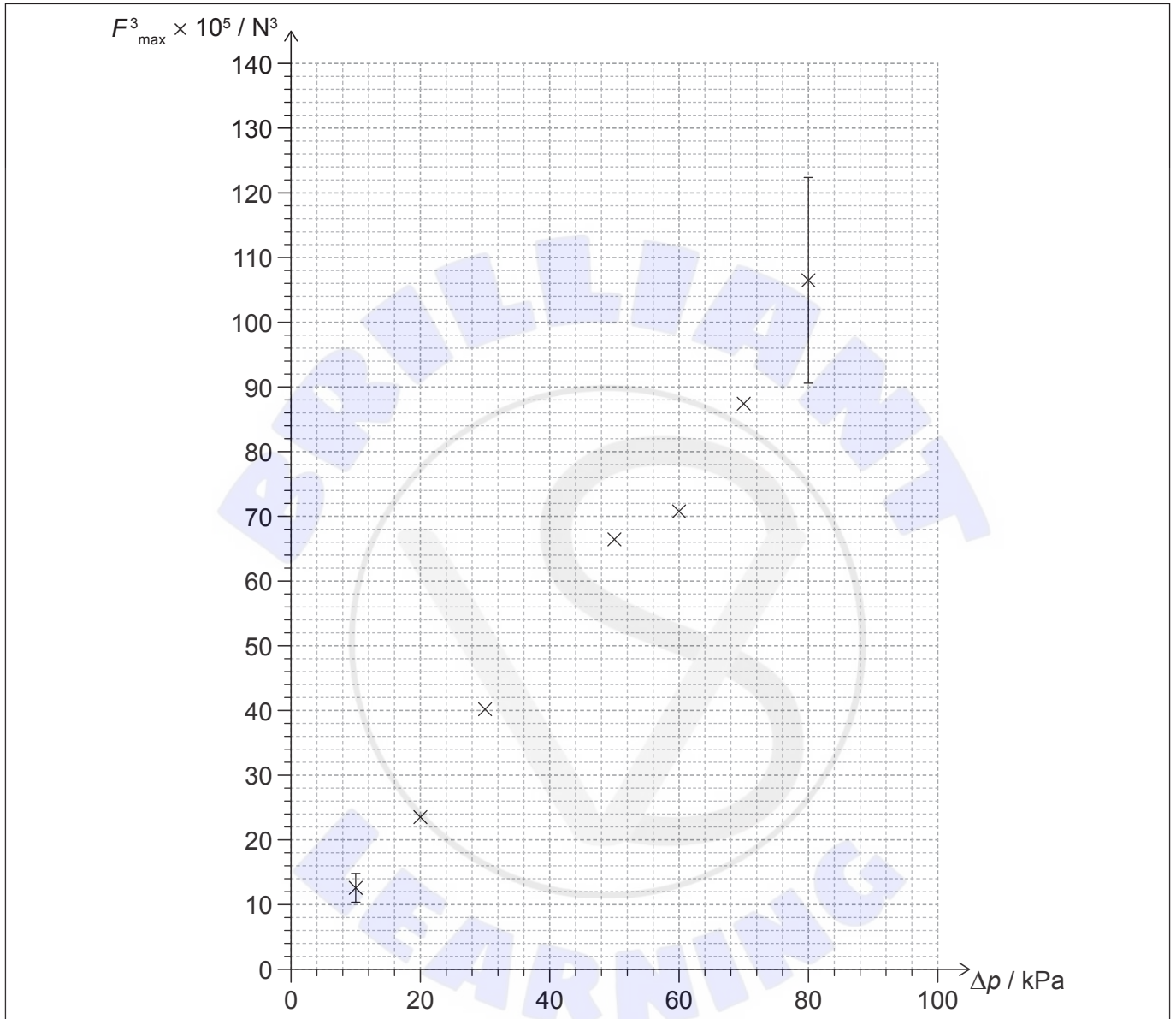

(c) (i) State the unit for k . [1]

.....

(ii) Plot on the graph the position of the missing point for the Δp value of 40 kPa. [1]

(This question continues on the following page)



(Question 1 continued)

The percentage uncertainty in F_{\max} is $\pm 5\%$. The error bars for F_{\max}^3 at $\Delta p = 10 \text{ kPa}$ and $\Delta p = 80 \text{ kPa}$ are shown.

- (d) (i) Calculate the absolute uncertainty in F_{\max}^3 for $\Delta p = 30 \text{ kPa}$. State an appropriate number of significant figures for your answer. [3]

.....
.....
.....
.....
.....
.....

- (ii) Plot the absolute uncertainty determined in part (d)(i) as an error bar on the graph. [1]

- (iii) Explain why the new hypothesis is supported. [1]

.....
.....
.....
.....

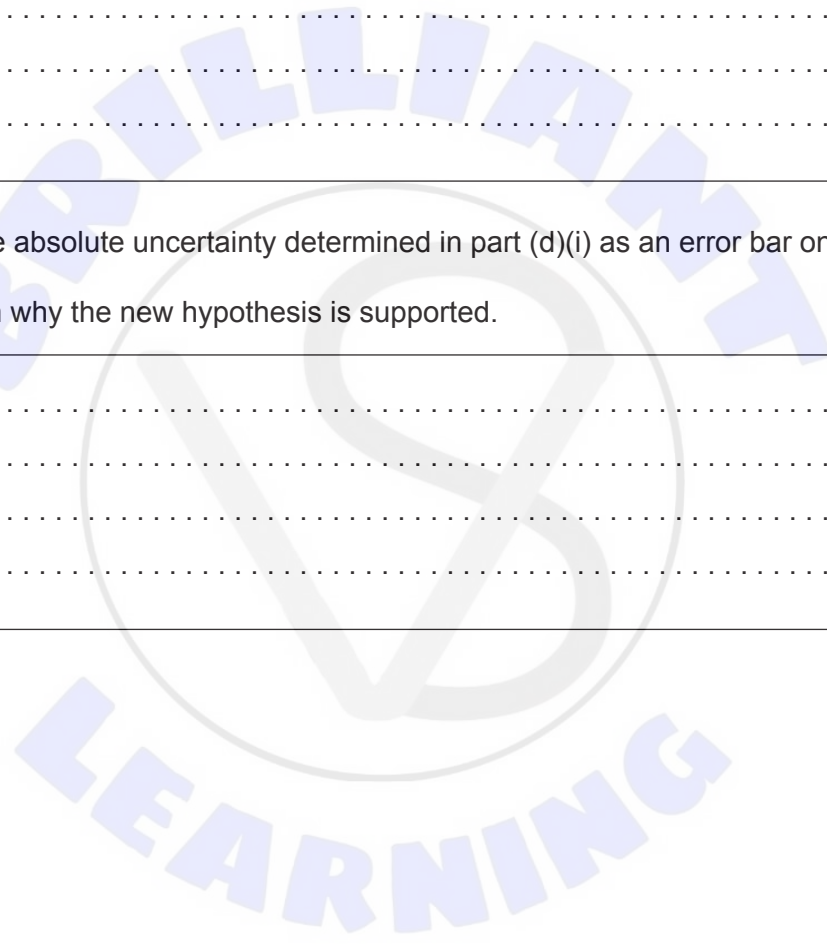

2. A student conducts an experiment to determine the specific heat capacity of a metal cube. The cube is heated in a beaker of boiling water to a temperature of 100°C and then quickly transferred into an insulated vessel of negligible thermal capacity. The vessel contains water at 20°C and of known specific heat capacity.

(a) State one other measurement that the student will need to make. [1]

.....
.....

(b) Suggest one modification that the student can make to reduce the fractional uncertainty for the change in temperature of the metal cube. [1]

.....
.....

(c) Some water from the beaker is accidentally transferred with the cube.
Discuss how this will affect the value of the calculated specific heat capacity of the cube. [2]

.....
.....
.....
.....

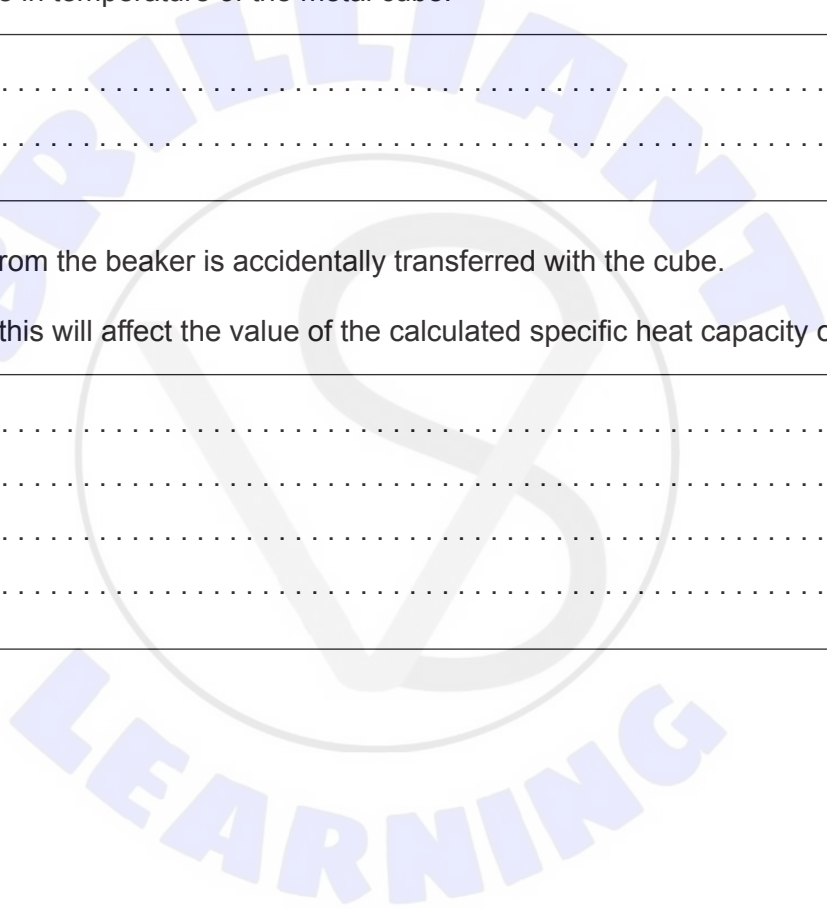

Section B

Answer **all** of the questions from **one** of the options. Answers must be written within the answer boxes provided.

Option A — Relativity

3. A wire carries an electric current. An external electron e moves with the drift velocity v of the electrons in the wire. Observer O is at rest relative to the wire.

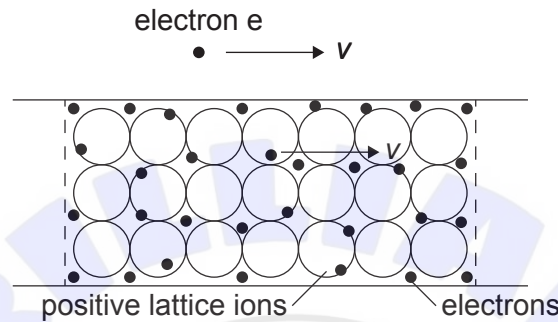

- (a) State what is meant by a frame of reference. [1]

.....

.....

- (b) State and explain the nature of the electromagnetic force acting on electron e in the frame of reference of

- (i) observer O . [2]

.....

.....

.....

.....

- (ii) electron e . [2]

.....

.....

.....

.....

(Option A continues on the following page)



(Option A continued)

4. Star A and star B are separated by a fixed distance of 4.8 light years as measured in the reference frame in which they are stationary. An observer P at rest in a space station moves to the right with speed $0.78c$ relative to the stars. A shuttle S travels from star A to star B at a speed of $0.30c$ relative to the stars.

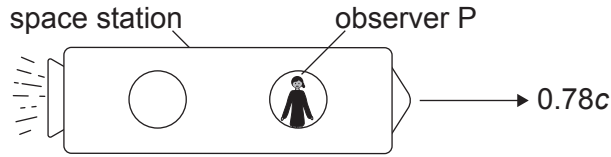

- (a) State the value of the maximum distance between the stars that can be measured in any reference frame. [1]

.....

.....

- (b) Write down the speed of shuttle S relative to observer P using Galilean relativity. [1]

.....

.....

- (c) Calculate the distance between star A and star B relative to observer P. [2]

.....

.....

.....

.....

(Option A continues on the following page)



(Option A, question 4 continued)

(d) Show that the speed of shuttle S relative to observer P is approximately $0.6c$. [2]

.....

.....

.....

.....

(e) Calculate the time, according to observer P, that the shuttle S takes to travel from star A to star B. [2]

.....

.....

.....

.....

(f) Identify and explain the reference frame in which the proper time for shuttle S to journey from star A to star B can be measured. [2]

.....

.....

.....

.....

(Option A continues on the following page)



(Option A continued)

5. The spacetime diagram shows the Earth frame with the worldline of a spaceship S moving away from Earth. $ct' = 0$ when $ct = 0$.

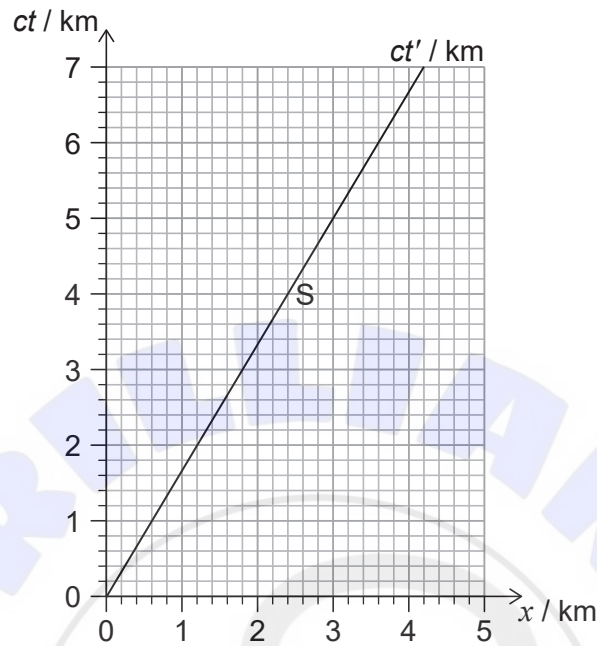

- (a) Determine the speed of the spaceship relative to Earth. [1]

.....
.....

A flash of light sent by an Earth observer at $ct = 2.0$ km is directed towards the spaceship.

- (b) Estimate, using the spacetime diagram, the time in seconds when the flash of light reaches the spaceship according to the Earth observer. [2]

.....
.....
.....
.....

(Option A continues on the following page)



(Option A, question 5 continued)

- (c) Determine the time coordinate ct' when the flash of light reaches the spaceship, according to an observer at rest in the spaceship.

[2]

.....

.....

.....

.....

.....

.....

(Option A continues on page 13)

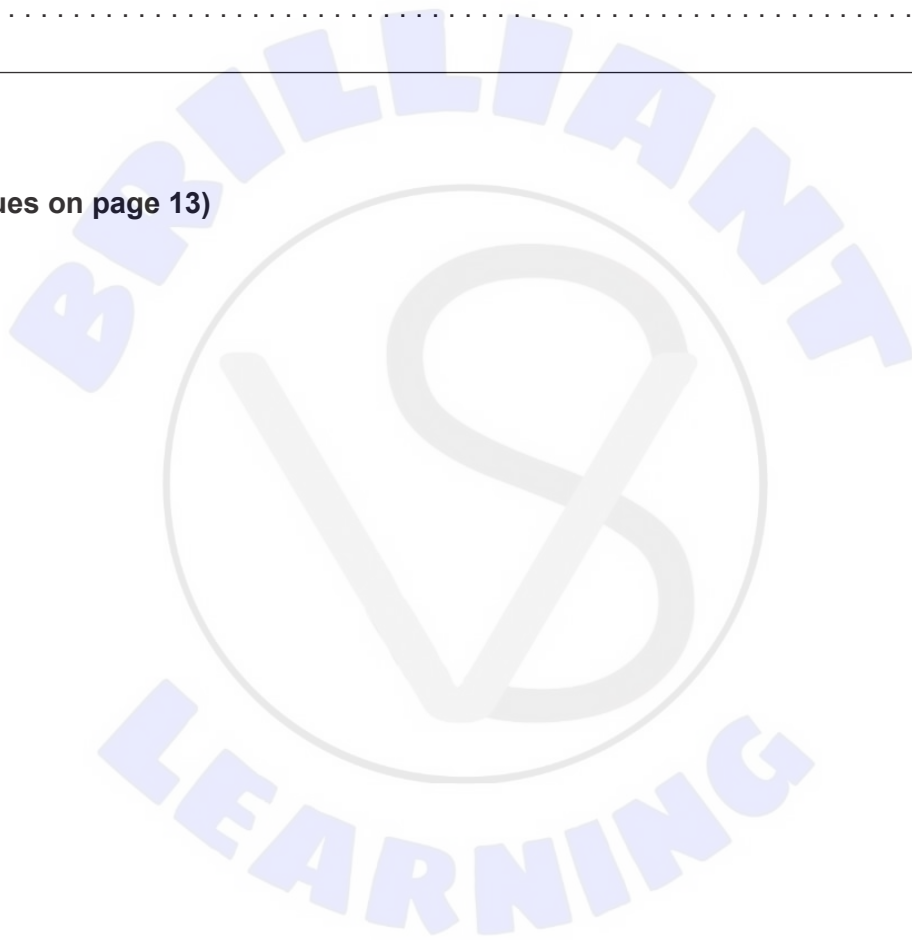



Please **do not** write on this page.

Answers written on this page
will not be marked.



(Option A continued)

6. In the laboratory frame of reference, a kaon decays spontaneously into a positive pion and a negative pion that then move in opposite directions.

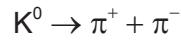

The rest mass of both the pions is $140\text{MeV}c^{-2}$. The π^+ has a momentum of magnitude $340\text{MeV}c^{-1}$ and the π^- has momentum of magnitude $113\text{MeV}c^{-1}$.

- (a) State the magnitude of the momentum of the K^0 the instant before it decays. [1]

.....
.....

- (b) Show that the energy of the π^+ is approximately 370MeV . [1]

.....
.....

- (c) Calculate the rest energy of the K^0 . [3]

.....
.....
.....
.....
.....
.....
.....
.....

(Option A continues on the following page)



(Option A continued)

7. A rocket ship is at rest on the surface of a non-rotating planet X. The rocket ship contains a chamber of height 20 m. Photons are emitted with frequency 3.2×10^{10} Hz and travel from the floor of the chamber to the ceiling of the chamber. A receiver on the ceiling detects the frequency of the photons.

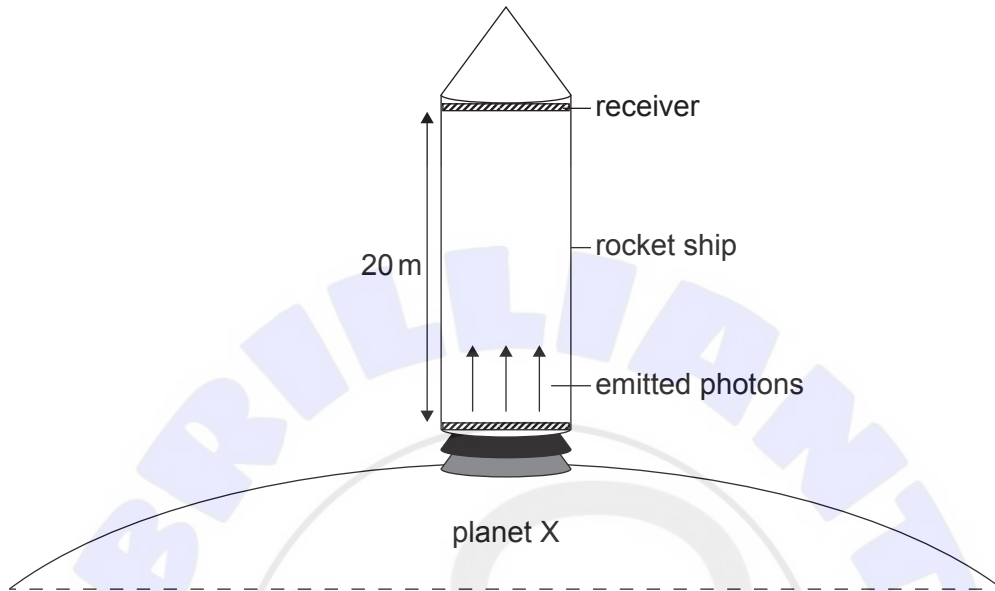

- (a) Explain why the frequency of the photons detected at the ceiling is less than the frequency of those emitted from the floor. [1]

.....

.....

- (b) The change in frequency detected at the ceiling as compared to the floor was measured to be 1.2×10^{-4} Hz. Deduce the gravitational field strength of planet X. [2]

.....

.....

.....

.....

(Option A continues on the following page)



(Option A, question 7 continued)

- (c) The rocket ship is launched and accelerates vertically. Explain, with reference to the equivalence principle, why the magnitude of the frequency change observed in photons emitted from floor to ceiling of the rocket ship will increase as it launches. [2]

.....

.....

.....

.....

End of Option A

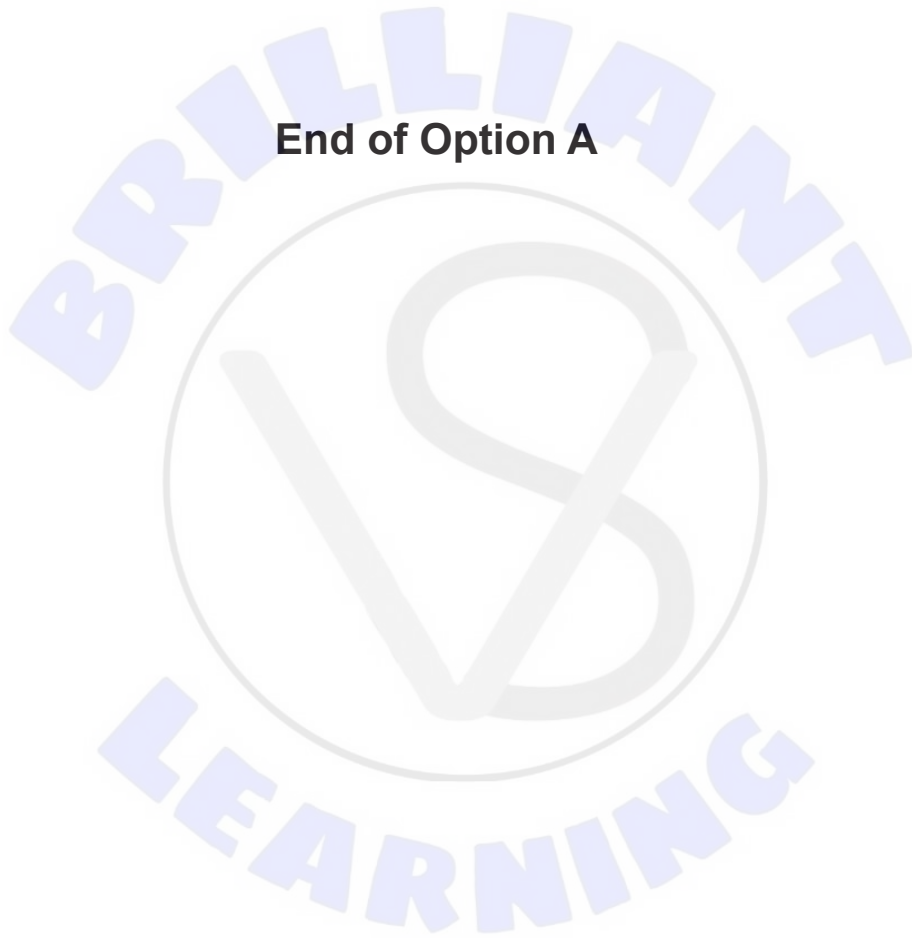

Option B — Engineering physics

8. A student models a rotating dancer using a system that consists of a vertical cylinder, a horizontal rod and two spheres.

The cylinder rotates from rest about the central vertical axis. A rod passes through the cylinder with a sphere on each side of the cylinder. Each sphere can move along the rod. Initially the spheres are close to the cylinder.

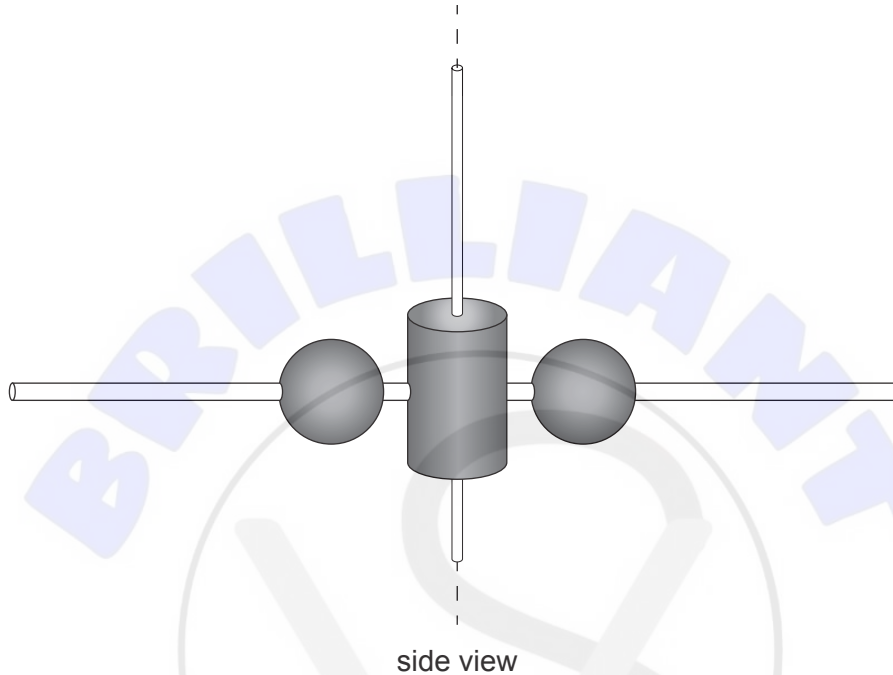

A horizontal force of 50 N is applied perpendicular to the rod at a distance of 0.50 m from the central axis. Another horizontal force of 40 N is applied in the opposite direction at a distance of 0.20 m from the central axis. Air resistance is negligible.

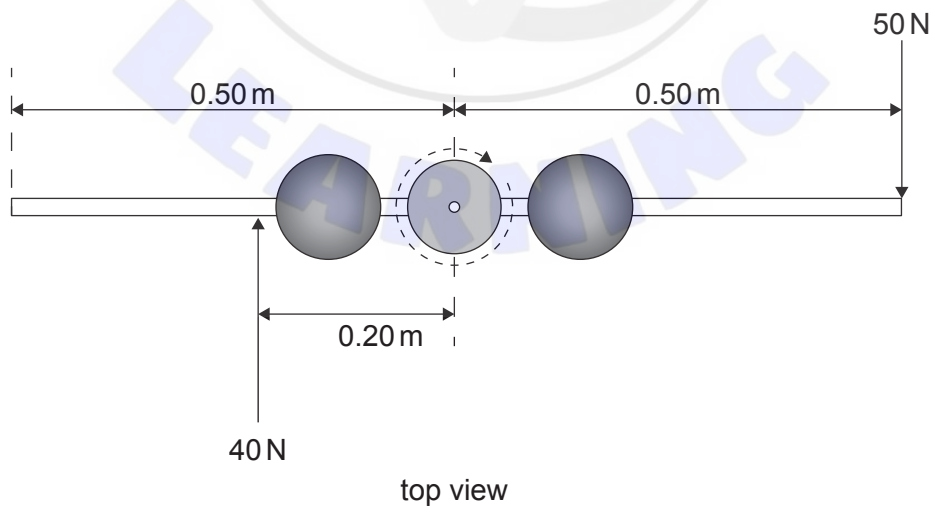

(Option B continues on the following page)



(Option B, question 8 continued)

- (a) Show that the net torque on the system about the central axis is approximately 30 Nm. [1]

.....
.....

- (b) The system rotates from rest and reaches a maximum angular speed of 20 rad s^{-1} in a time of 5.0 s. Calculate the angular acceleration of the system. [1]

.....
.....

- (c) Determine the moment of inertia of the system about the central axis. [2]

.....
.....
.....
.....

(Option B continues on the following page)

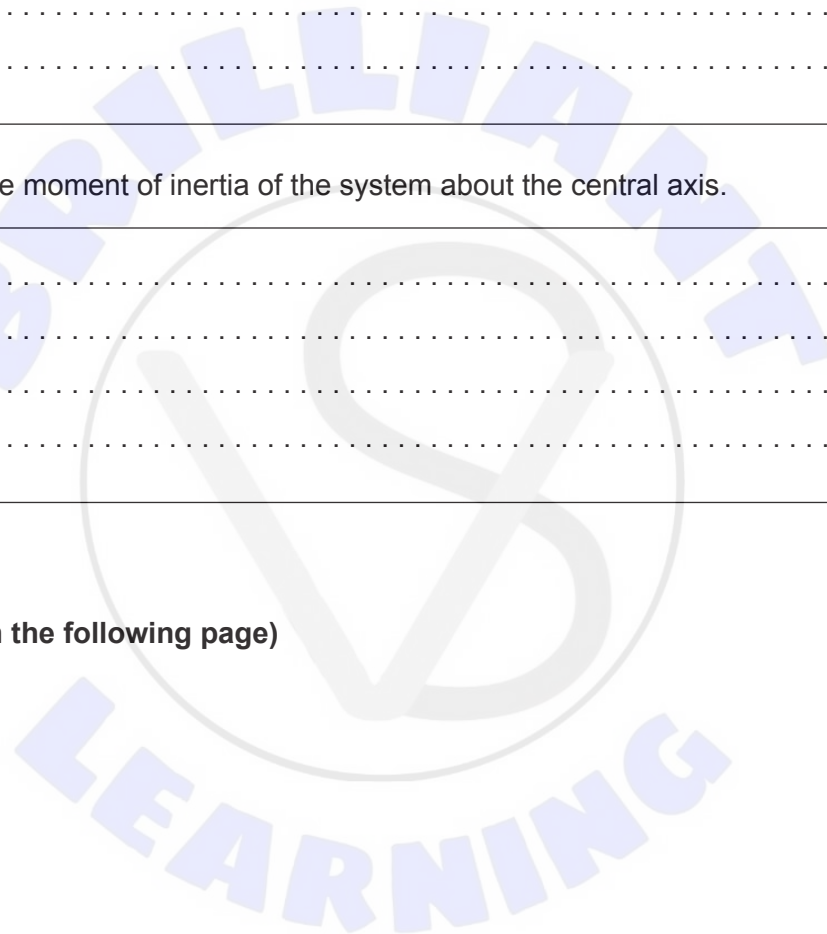

(Option B, question 8 continued)

- (d) When the system has reached its maximum angular speed, the two forces are removed. The spheres now move outward, away from the central axis.

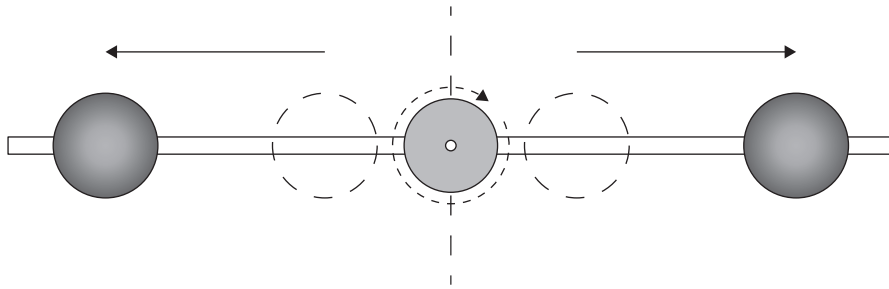

- (i) Outline why the angular speed ω decreases when the spheres move outward. [2]

.....

.....

.....

.....

- (ii) Show that the rotational kinetic energy is $\frac{1}{2}L\omega$ where L is the angular momentum of the system. [1]

.....

.....

- (iii) When the spheres move outward, the angular speed decreases from 20 rad s^{-1} to 12 rad s^{-1} . Calculate the percentage change in rotational kinetic energy that occurs when the spheres move outward. [2]

.....

.....

.....

.....

.....

.....

(Option B continues on the following page)



(Option B, question 8 continued)

(e) Outline one reason why this model of a dancer is unrealistic.

[1]

.....

.....

(Option B continues on the following page)



(Option B continued)

9. A frictionless piston traps a fixed mass of an ideal gas. The gas undergoes three thermodynamic processes in a cycle.

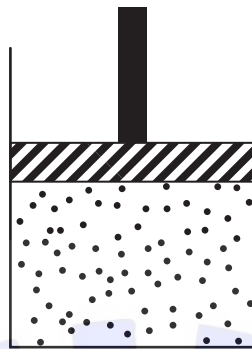

The initial conditions of the gas at A are:

volume = 0.330 m^3
pressure = 129 kPa
temperature = $27.0 \text{ }^\circ\text{C}$

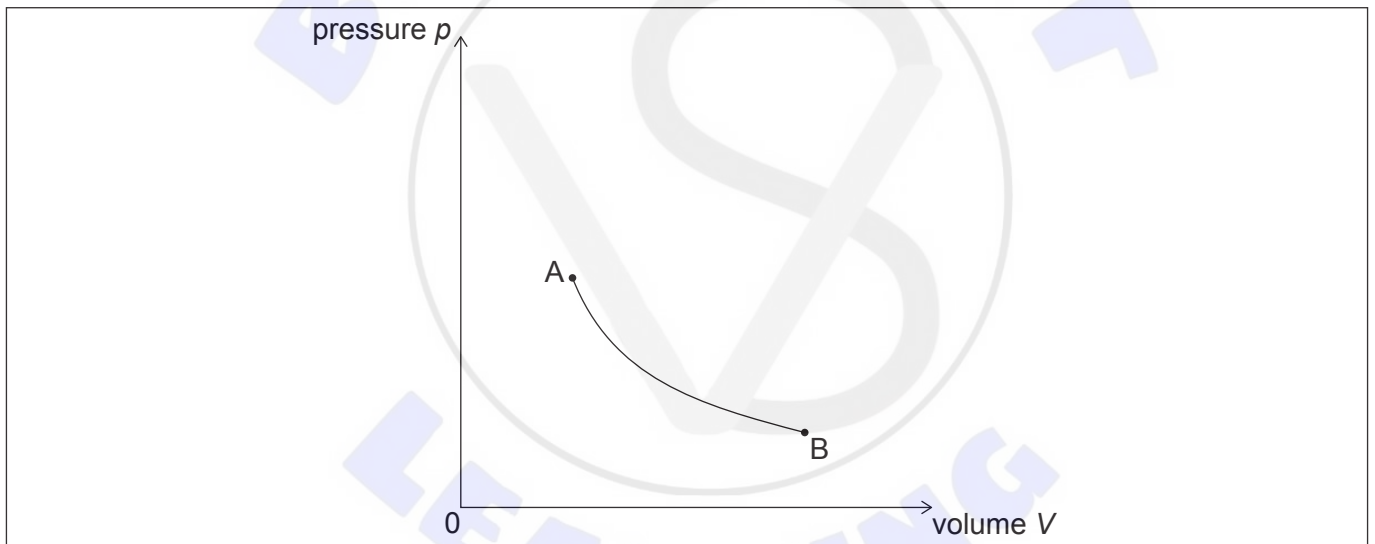

Process AB is an isothermal change, as shown on the pressure volume (pV) diagram, in which the gas expands to three times its initial volume.

- (a) Calculate the pressure of the gas at B. [2]

.....

.....

.....

.....

(Option B continues on the following page)



(Option B, question 9 continued)

The gas now undergoes adiabatic compression BC until it returns to the initial volume. To complete the cycle, the gas returns to A via the isovolumetric process CA.

- (b) Sketch, on the pV diagram, the remaining two processes BC and CA that the gas undergoes. [2]
- (c) Show that the temperature of the gas at C is approximately 350°C . [2]

.....

.....

.....

.....

.....

.....

.....

- (d) Explain why the change of entropy for the gas during the process BC is equal to zero. [1]

.....

.....

- (e) Explain why the work done by the gas during the isothermal expansion AB is less than the work done on the gas during the adiabatic compression BC. [1]

.....

.....

- (f) The quantity of trapped gas is 53.2 mol. Calculate the thermal energy removed from the gas during process CA. [2]

.....

.....

.....

.....

(Option B continues on the following page)



(Option B continued)

10. A large tank is used to store oil of density 850 kg m^{-3} and is filled to a height h_1 above the bottom. A valve in the tank wall allows oil to flow out. The centre of the valve is at a height h_2 from the bottom of the tank. A circular drainage outlet is at the bottom of the tank.

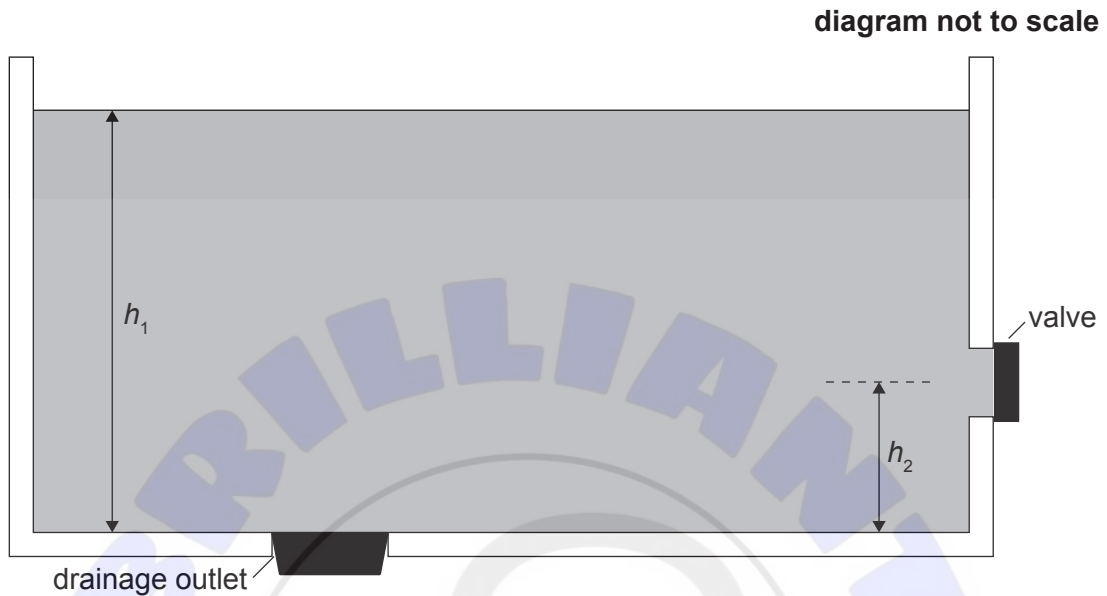

The drainage outlet has a diameter of 100 mm and a metal stopper of mass 2.5 kg is used to plug the outlet.

- (a) Determine the minimum force required to lift the stopper when $h_1 = 4.0 \text{ m}$. [3]

.....

.....

.....

.....

.....

.....

.....

(Option B continues on the following page)



(Option B, question 10 continued)

With the metal stopper in place, the valve on the side of the tank is opened to let oil flow out.

Using Bernoulli's equation, it can be shown that the speed v of oil flowing through the valve can be estimated as $v = \sqrt{2g(h_1 - h_2)}$.

- (b) State **two** assumptions that were used in obtaining the expression for the speed v . [2]

.....

.....

.....

.....

- (c) Estimate the maximum radius of the valve so that turbulent flow does not occur. The following data are given: [2]

Viscosity of oil = 0.25 Pa s
 $h_1 = 4.0$ m
 $h_2 = 0.5$ m

.....

.....

.....

.....

.....

.....

(Option B continues on page 25)





Please **do not** write on this page.

Answers written on this page
will not be marked.



(Option B continued)

11. A mass vibrating on a vertical spring is driven by a sinusoidal force. The graph shows the variation of the amplitude of vibration with driving frequency for the mass. The damping initially applied to the vibrating system has a Q factor of 50.

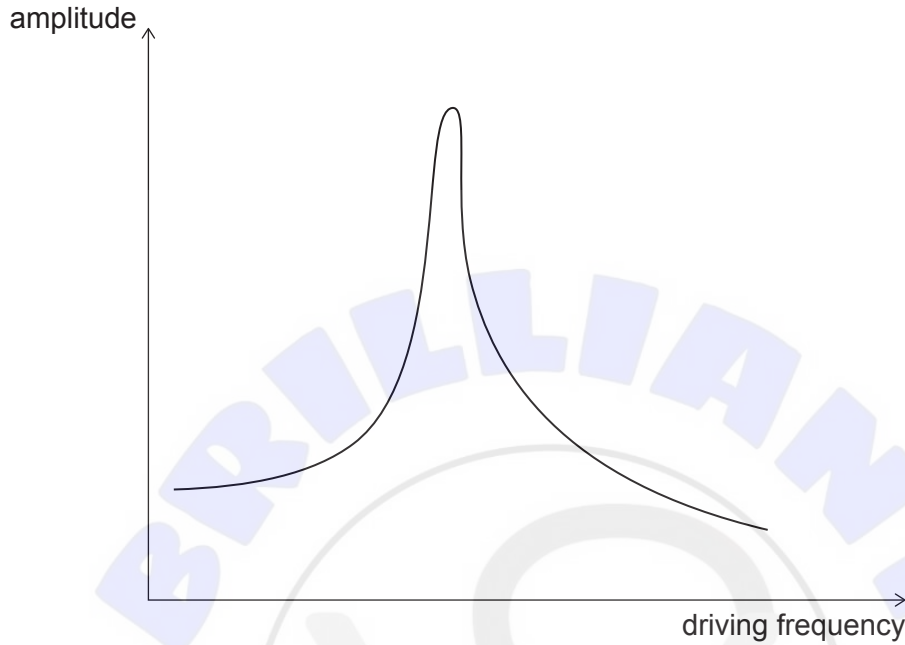

- (a) The damping is changed so that the Q factor is decreased. State and explain **one** change to the graph. [2]

.....

.....

.....

.....

- (b) The driving force is removed and the spring now oscillates freely with a Q factor of 30. Calculate the fraction of the total energy that has dissipated after one cycle is completed. [1]

.....

.....

End of Option B



Option C — Imaging

12. An object is placed in front of a concave mirror with the focal point f as shown.

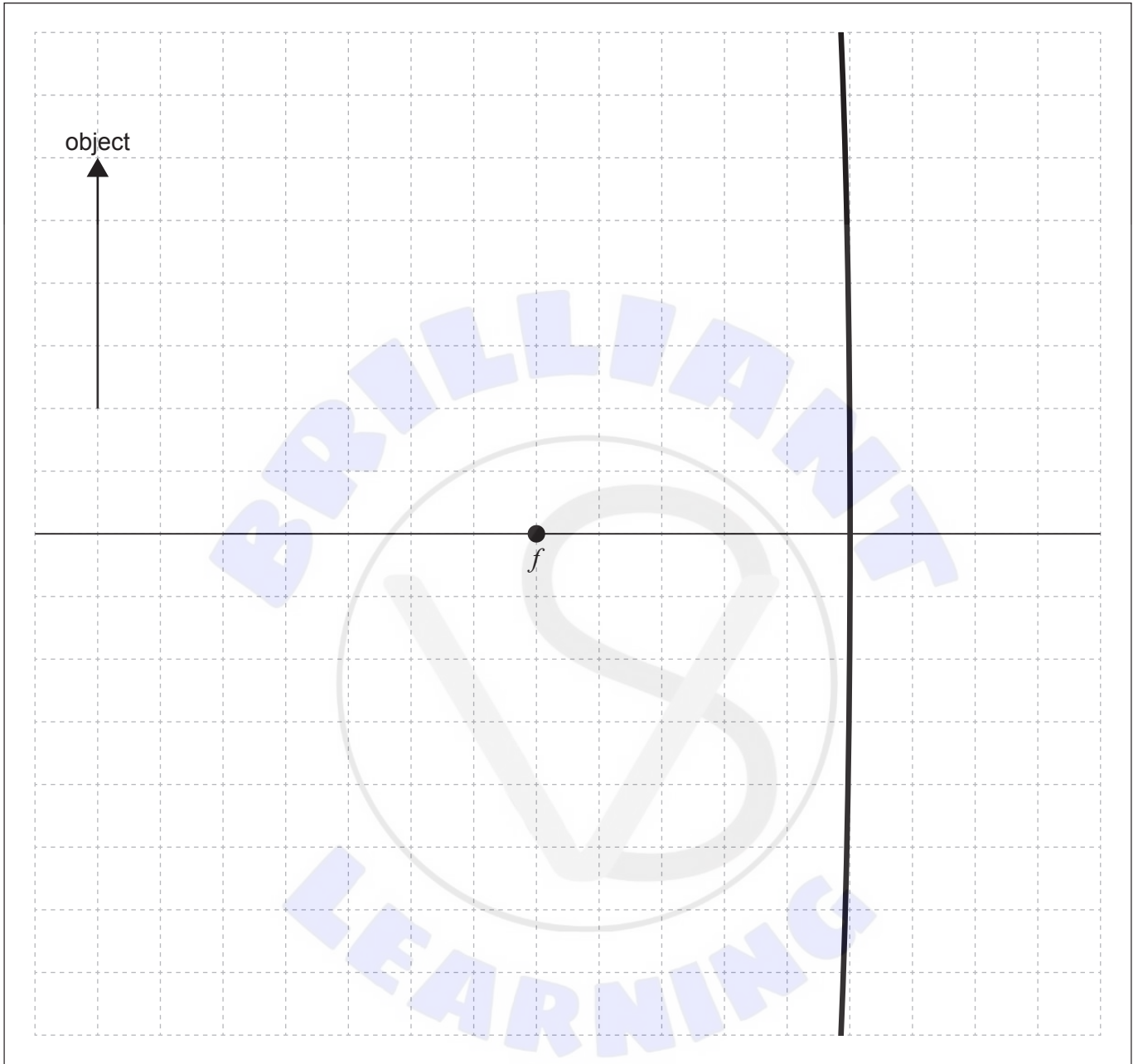

(a) Construct a ray diagram to locate the position of the image produced.

[2]

(Option C continues on the following page)



(Option C, question 12 continued)

(b) Describe the features of the image produced.

[1]

.....
.....

(c) Parallel light rays are incident on a spherical concave mirror as shown.

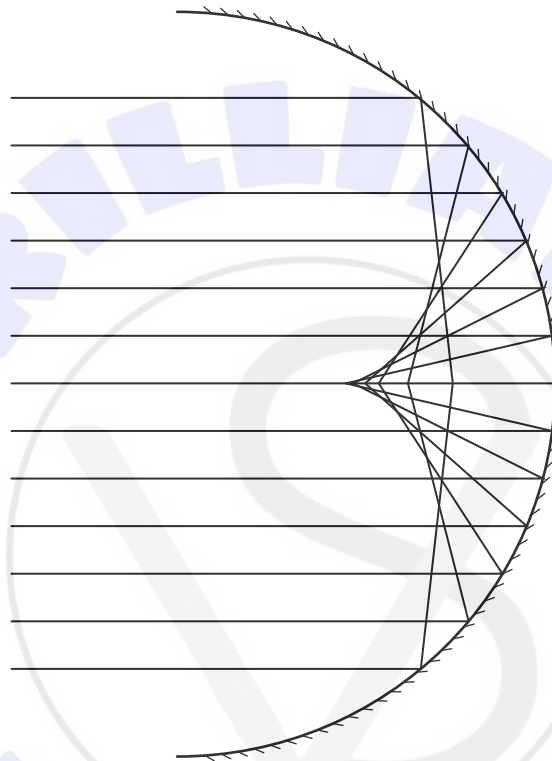

State the problem illustrated by the diagram and how it is corrected in reflecting telescopes.

[2]

.....
.....
.....
.....

(Option C continues on the following page)



(Option C continued)

13. The eye of an observer has a near point of 25 cm. A pencil is placed at the near point. A convex lens of focal length 8 cm is then placed between the pencil and the observer as shown. The pencil is positioned at the focal point of the lens.

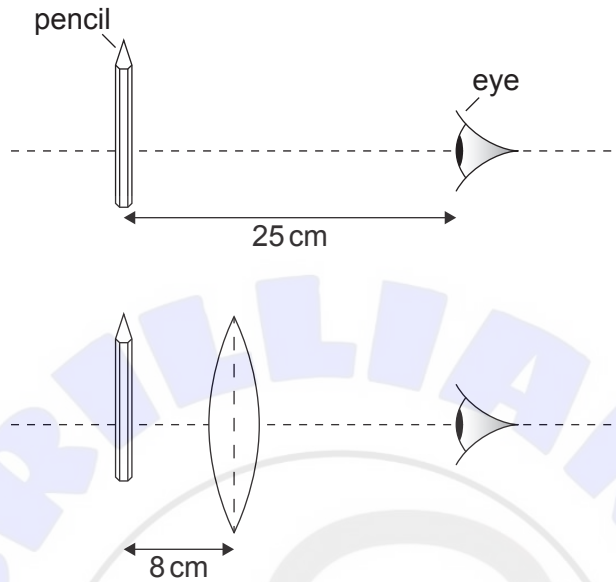

- (a) Determine the angular magnification of the lens when the image of the pencil is viewed at infinity. [1]

.....

.....

- (b) A student increases the magnification of the pencil by using two 8 cm focal length convex lenses placed 25 cm apart. The pencil is placed 14 cm from one of the lenses.



(Option C continues on the following page)



(Option C, question 13 continued)

- (i) Show that the magnitude of the magnification of the pencil produced by the lens closest to the pencil is approximately 1.3. [2]

.....

.....

.....

.....

- (ii) Calculate the total magnification observed by the student using the two lenses as shown. [2]

.....

.....

.....

.....

(c) The two 8 cm focal length convex lenses are now used to construct a telescope in normal adjustment. The diameter of the lenses is much greater than the diameter of the pupil of the eye. State, compared with the naked eye,

- (i) **one** advantage of using this telescope for astronomical observations. [1]

.....

.....

- (ii) **one** disadvantage of using this telescope for astronomical observations. [1]

.....

.....

(Option C continues on page 31)





Please **do not** write on this page.

Answers written on this page
will not be marked.



(Option C, question 13 continued)

- (d) Describe how international collaboration can improve the quality of the image of radio array telescopes.

[2]

.....

.....

.....

.....

(Option C continues on the following page)

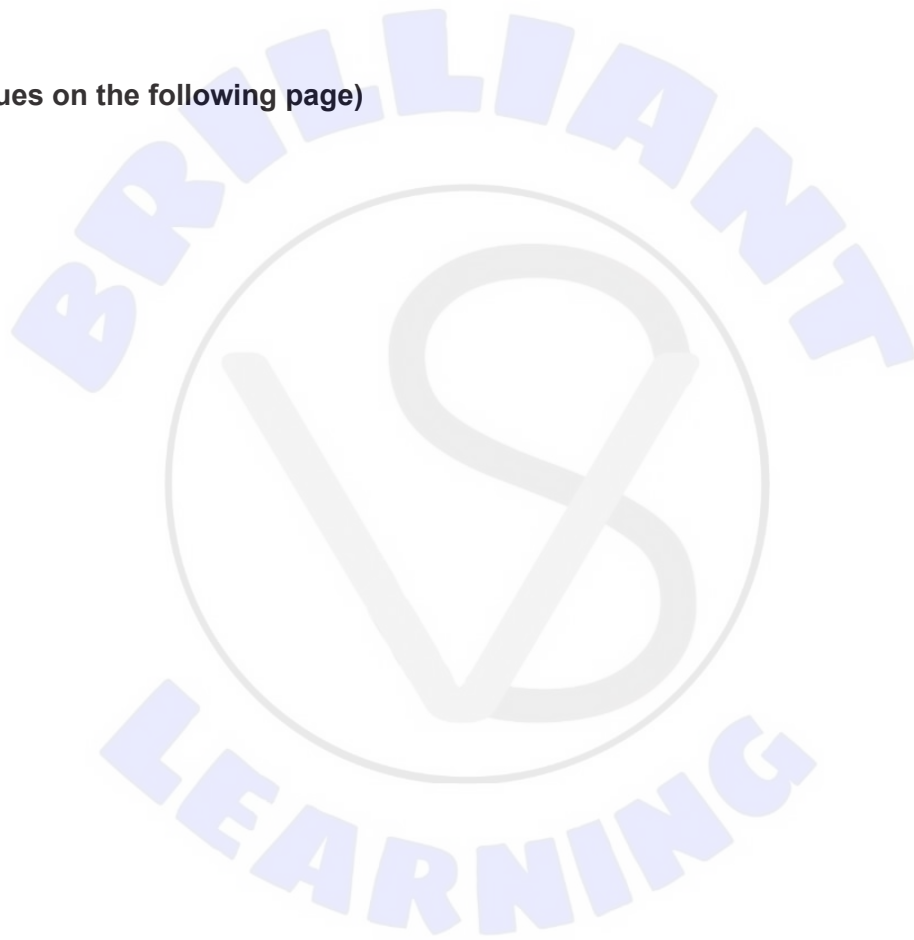

(Option C continued)

14. Signals in an optic fibre require amplification when intensity levels in the fibre have fallen to 1.5% of the original signal. A light signal of initial intensity I_0 is sent down the optic fibre.

- (a) The fibre has an attenuation per unit length of 0.30 dB km^{-1} . Deduce that the length of the fibre is approximately 60 km before the signal requires amplification. [2]

.....
.....
.....
.....

A signal is sent down a 27 km step-index fibre and received according to the intensity–time graph below.

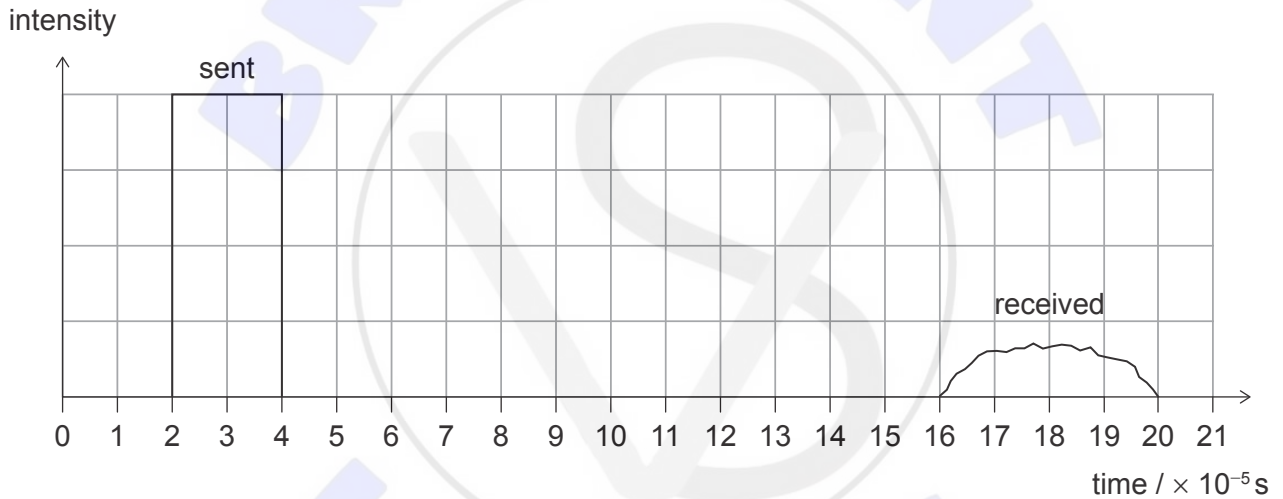

- (b) Calculate the refractive index of the fibre. [2]

.....
.....
.....
.....

(Option C continues on the following page)



(Option C, question 14 continued)

(c) Discuss how using a graded-index fibre could reduce waveguide dispersion. [2]

.....

.....

.....

.....

(Option C continues on the following page)



(Option C continued)

15. The X-ray attenuation coefficient values for bone and muscle at an energy of 100 keV are shown.

$$\begin{aligned} \text{Bone attenuation coefficient} &= 0.348 \text{ cm}^{-1} \\ \text{Muscle attenuation coefficient} &= 0.173 \text{ cm}^{-1} \end{aligned}$$

(a) Show that the half-value thickness of bone when using X-ray energies of 100 keV is approximately 2 cm. [1]

.....

.....

A monochromatic X-ray beam of energy 100 keV and intensity I_0 is incident on muscle of thickness 4.0 cm.

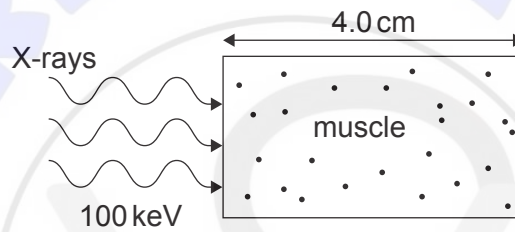

(b) Calculate, in terms of I_0 , the final beam intensity that emerges from the muscle. [2]

.....

.....

.....

.....

(Option C continues on the following page)



(Option C, question 15 continued)

An X-ray beam of energy 100 keV and intensity I_0 is directed at a section of the upper leg that can be modelled using 4.0 cm of muscle, 2.0 cm of bone and then 4.0 cm of muscle as shown.

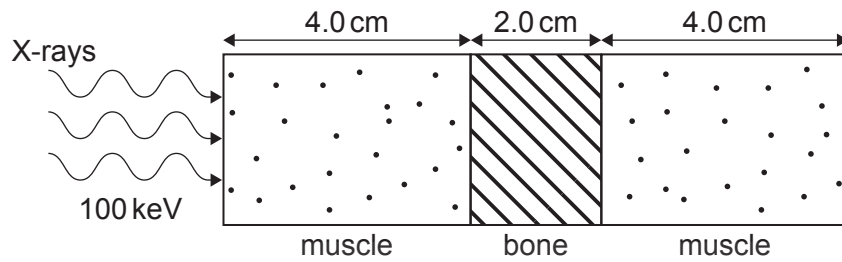

- (c) Determine, in terms of I_0 , the final beam intensity that emerges from this section of the upper leg. [2]

.....

.....

.....

.....

Additional attenuation coefficient values for bone and muscle are shown for X-ray energies of 1 keV and 10 keV.

Energy of X-rays / keV	Bone attenuation coefficient / cm^{-1}	Muscle attenuation coefficient / cm^{-1}
1	7260	3910
10	55.9	56.2

- (d) Compare, with reference to contrast and sharpness, the final images formed when X-rays of 1 keV or 10 keV are incident on the same muscle–bone–muscle section of the upper leg. [2]

.....

.....

.....

.....

(Option C continues on page 37)





Please **do not** write on this page.

Answers written on this page
will not be marked.



(Option C, question 15 continued)

(e) Other medical imaging techniques include ultrasound and nuclear magnetic resonance (NMR) imaging.

(i) State **one** difference between an A scan and a B scan in ultrasound medical imaging. [1]

.....
.....

(ii) Explain how position information is obtained in nuclear magnetic resonance (NMR) imaging. [2]

.....
.....
.....
.....

End of Option C

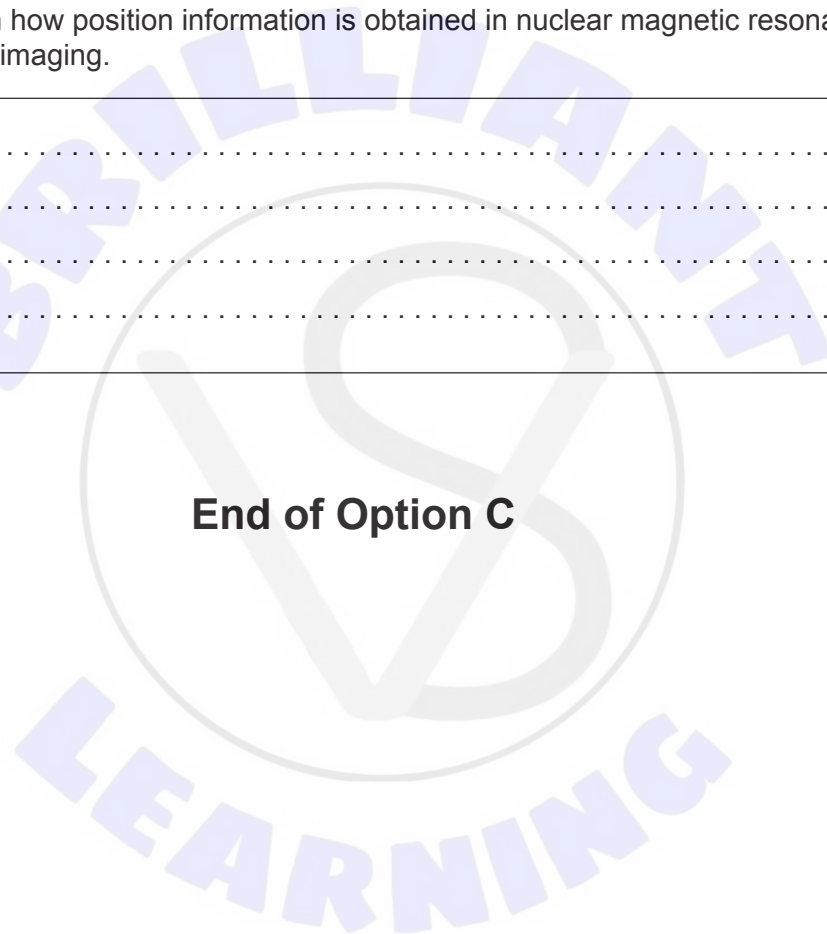

Option D — Astrophysics

16. (a) The Ghost of Jupiter is a nebula.

(i) Outline what is meant by a nebula.

[1]

.....
.....

(ii) Astrophysicists have deduced the nature of this nebula from Earth. Outline how they can make these deductions.

[1]

.....
.....

(b) Star X and star Y are in our own galaxy. They appear to move with respect to very distant stars when viewed from Earth during a six-month period. The following data are provided.

	Parallax angle	Apparent brightness
Star X	0.019 arc-second	$8.4 \times 10^{-9} \text{W m}^2$
Star Y	0.038 arc-second	$3.1 \times 10^{-9} \text{W m}^2$

(i) Deduce which star will appear to move more.

[2]

.....
.....
.....
.....

(ii) Calculate, in m, the distance to star X.

[1]

.....
.....

(Option D continues on the following page)



(Option D, question 16 continued)

(iii) Determine the ratio $\frac{\text{luminosity of star X}}{\text{luminosity of star Y}}$. [2]

.....

.....

.....

.....

.....

.....

.....

(Option D continues on the following page)

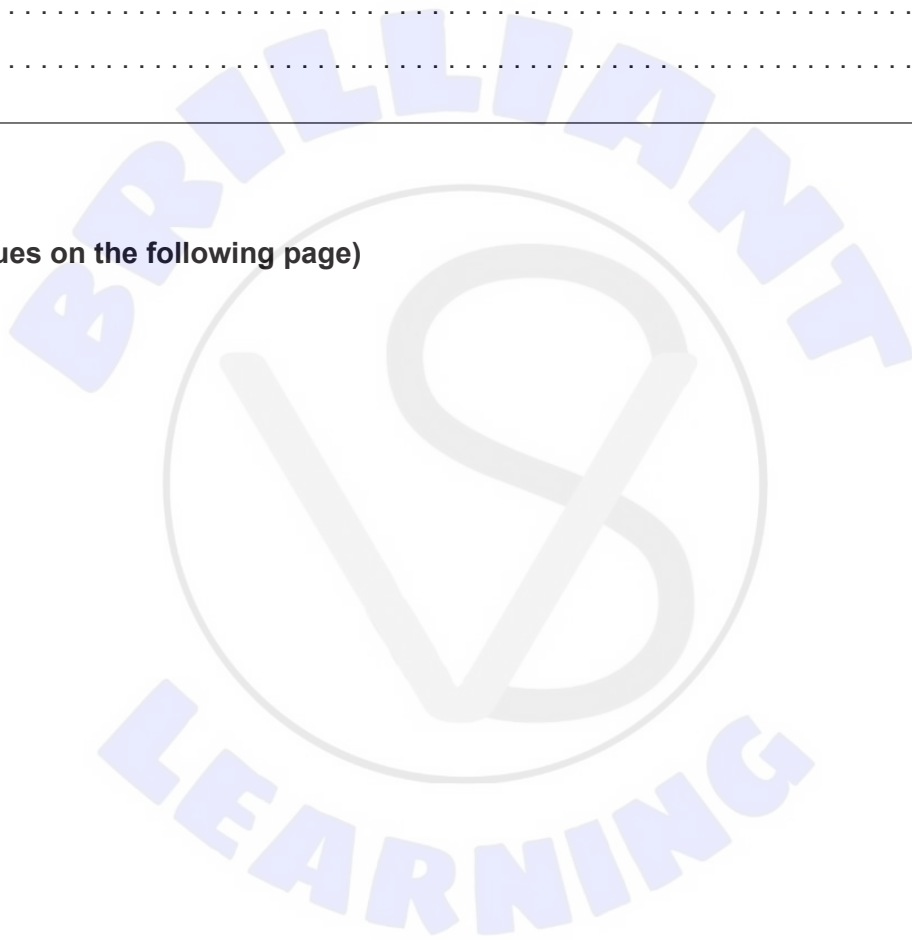

(Option D continued)

17. Three stars A, B and C are labelled on the Hertzsprung–Russell (HR) diagram. L_{\odot} is the Luminosity of the sun.

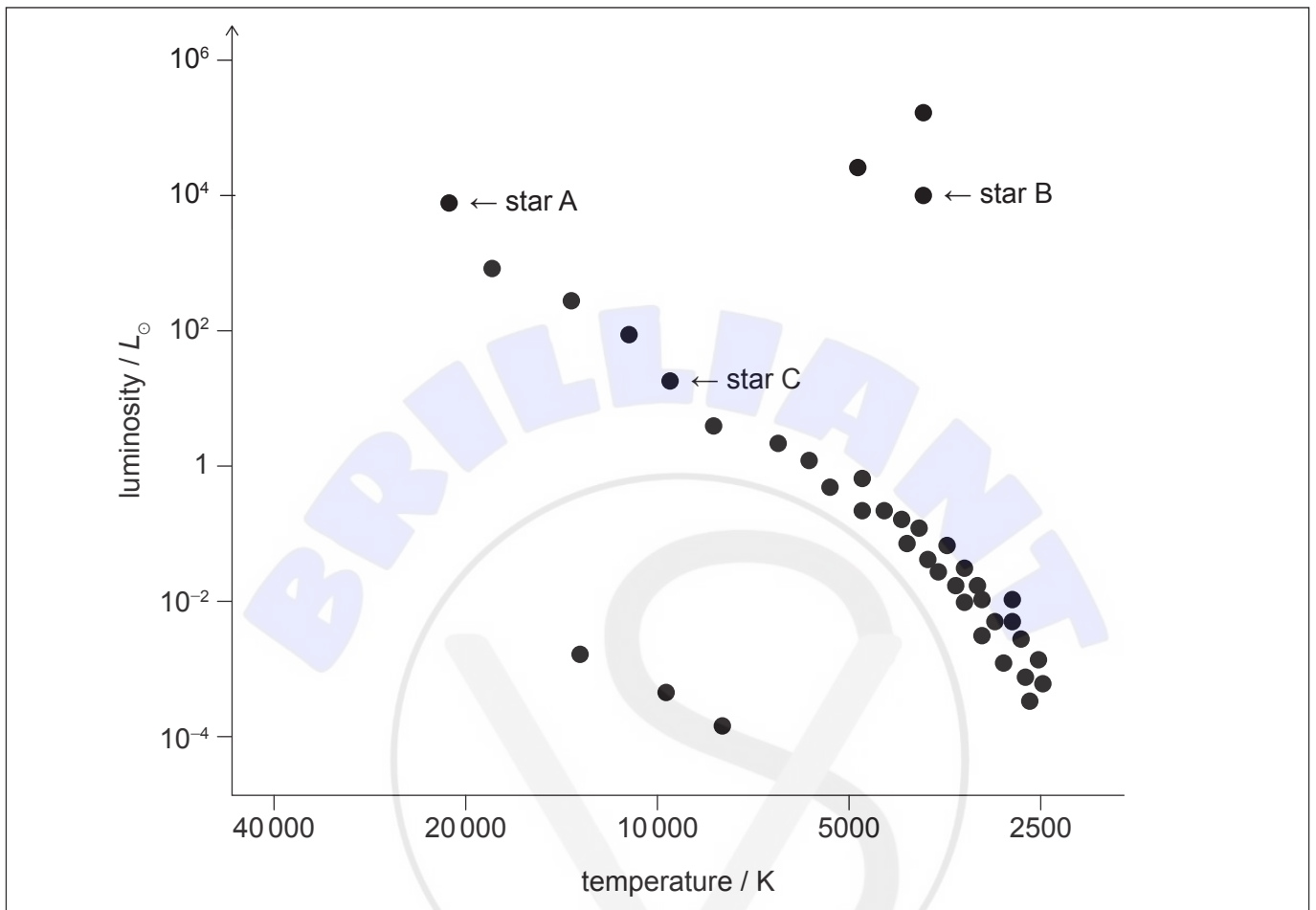

(a) State the main element that is undergoing nuclear fusion in star C. [1]

.....
.....

(b) Explain why star B has a greater surface area than star A. [2]

.....
.....
.....
.....

(Option D continues on the following page)



(Option D, question 17 continued)

- (c) White dwarfs with similar volumes to each other are shown on the HR diagram.

Construct a line, on the HR diagram, to show the possible positions of other white dwarf stars with similar volumes to those marked on the HR diagram. [2]

- (d) Some stars on the HR diagram are likely to evolve into neutron stars.

Outline why the radius of a neutron star reaches a stable value. [2]

.....

.....

.....

.....

(Option D continues on the following page)

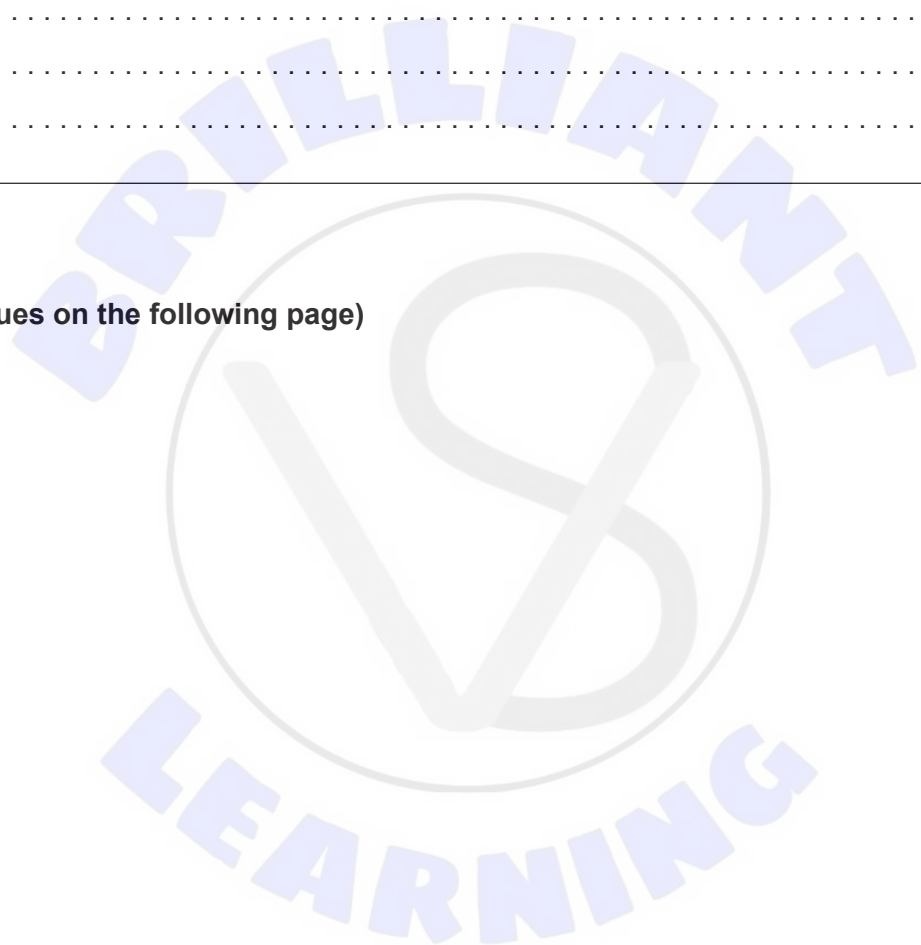

(Option D continued)

18. Galaxy D has a redshift $z = 0.13$.

(a) Calculate, in Mpc, the distance to D using a Hubble constant value of $73 \text{ km s}^{-1} \text{ Mpc}^{-1}$. [2]

.....
.....
.....
.....

(b) A Hubble constant value of $73 \text{ km s}^{-1} \text{ Mpc}^{-1}$ gives an age of the universe to be 13.4×10^9 years when assuming a constant rate of expansion has occurred.

(i) Determine in years, the age of the universe when the light detected on Earth now was originally emitted from D. [3]

.....
.....
.....
.....
.....
.....

(ii) Evidence based on observations of type Ia supernovae affects the result in (b)(i). State the relevant conclusion from these observations. [1]

.....
.....

(Option D continues on the following page)



(Option D continued)

19. (a) State the Jeans criterion for the collapse of interstellar clouds. [1]

.....
.....

- (b) For a main sequence star, the energy it releases during the total time T it spends on the main sequence is proportional to its mass M .

- (i) Show that $T \propto \frac{1}{M^{2.5}}$. [2]

.....
.....
.....
.....

- (ii) For the Sun, $T = 10^{10}$ years. Calculate T for a star 20 times more massive than the Sun. [1]

.....
.....
.....

(Option D continues on the following page)



(Option D continued)

20. (a) Determine the critical density of the universe using a Hubble constant value of $73 \text{ km s}^{-1} \text{ Mpc}^{-1}$. [2]

.....

.....

.....

.....

- (b) Sketch, on the axes shown, the variation of R/R_0 (the cosmic scale factor R divided by its present value R_0) with time for a universe where the density is greater than the critical density. [2]

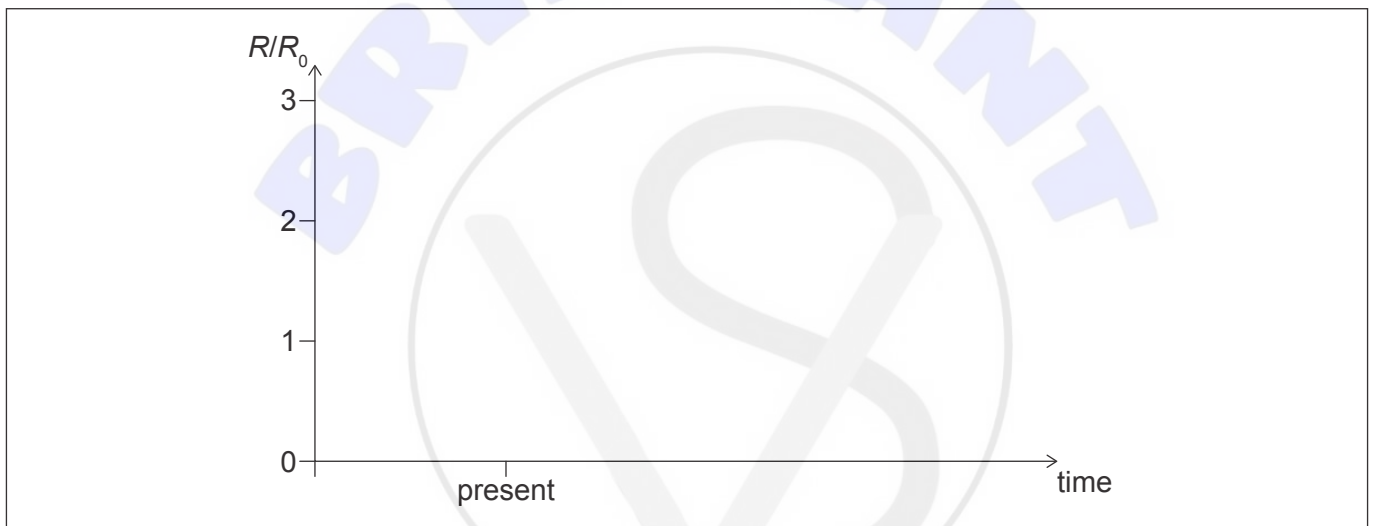

- (c) Explain how the presence of dark energy is likely to affect the future rate of temperature change of the universe. [2]

.....

.....

.....

.....

End of Option D

References:

© International Baccalaureate Organization 2023

